

CLUTCH SYSTEM/GEARSHIFT LINKAGE

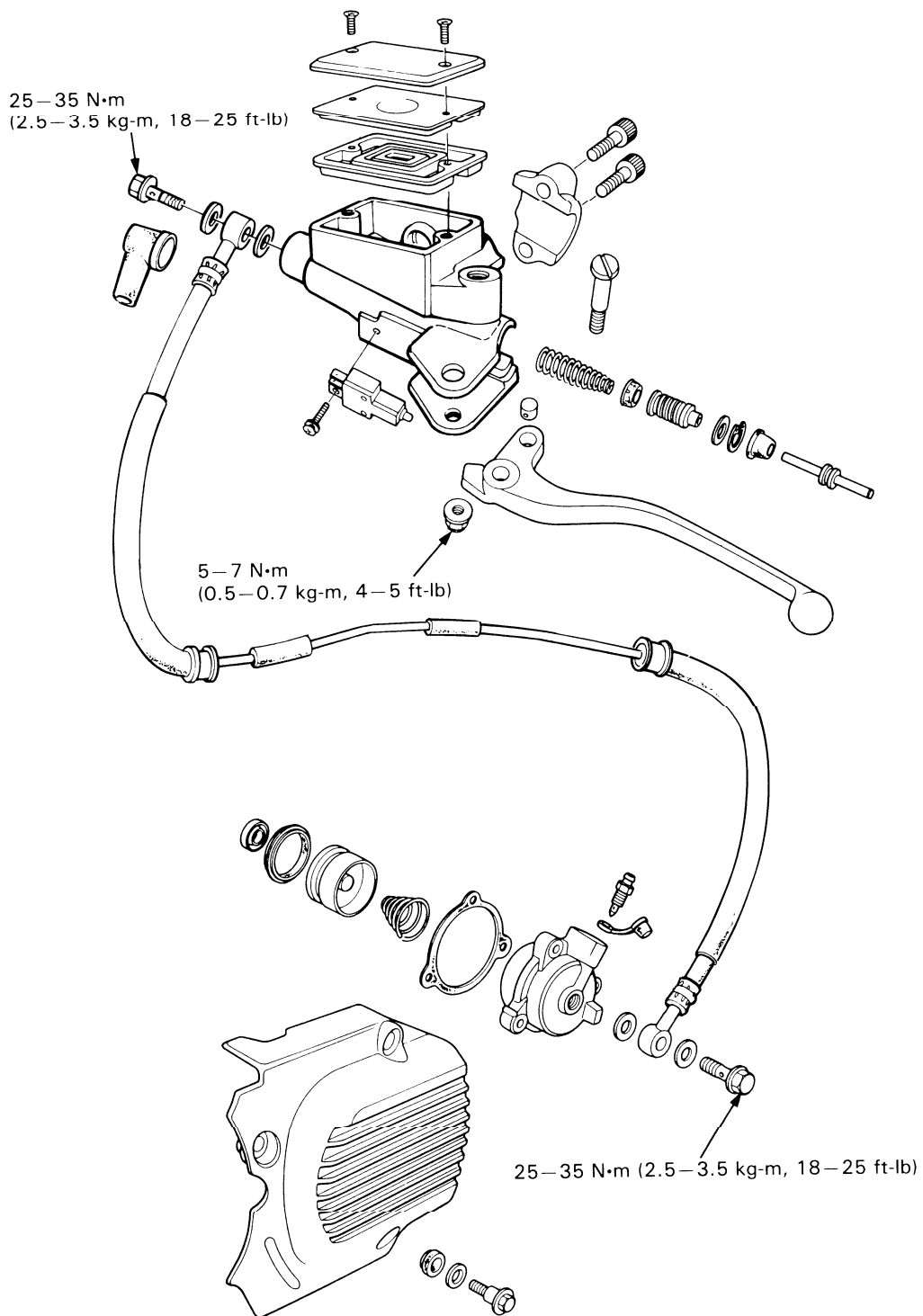

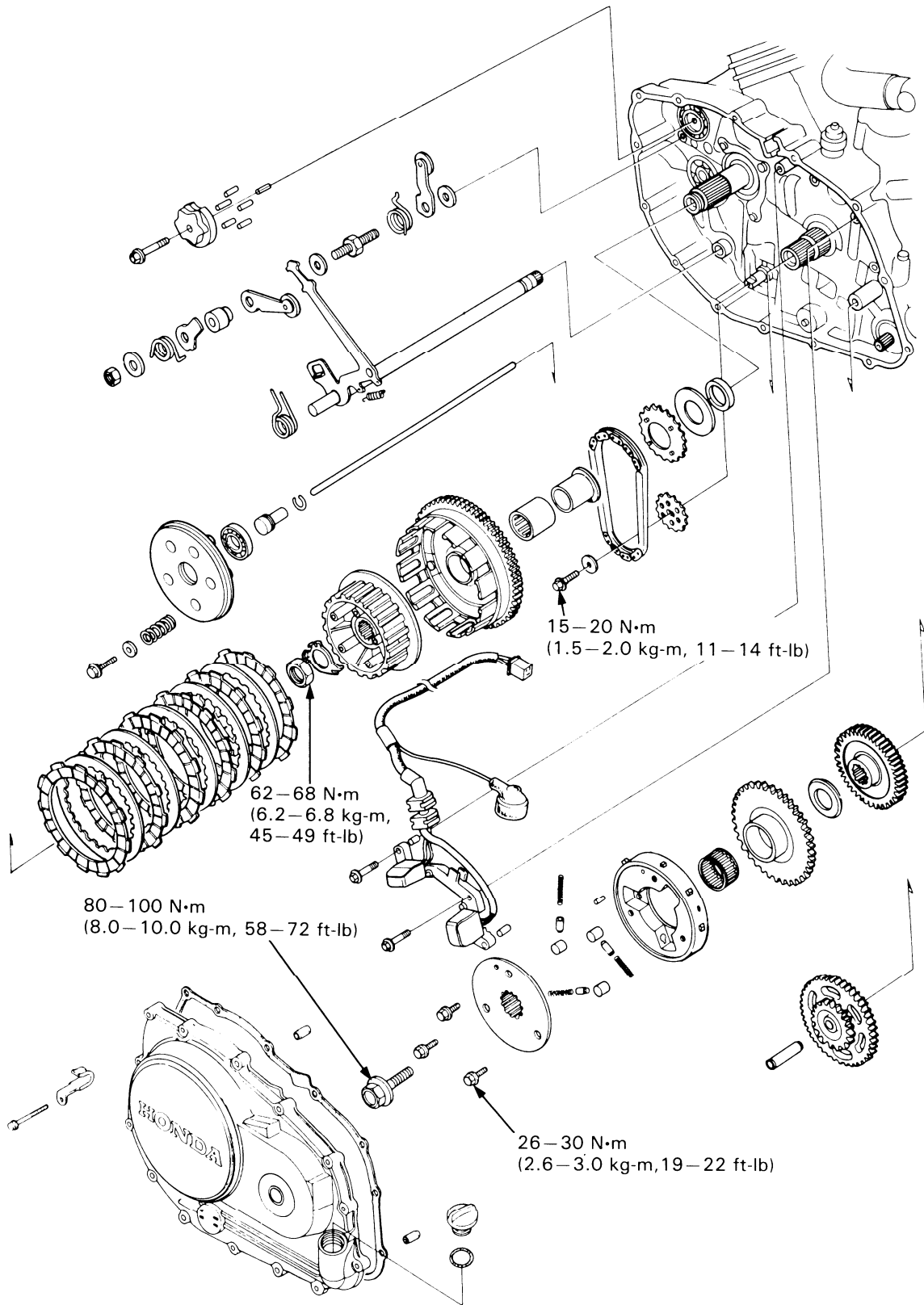

7. CLUTCH SYSTEM/GEARSHIFT LINKAGE

SERVICE INFORMATION	7-2	RIGHT CRANKCASE COVER REMOVAL	7-10
TROUBLESHOOTING	7-3	STARTER CLUTCH	7-11
CLUTCH FLUID REPLACEMENT/AIR BLEEDING	7-4	CLUTCH	7-14
CLUTCH MASTER CYLINDER	7-5	RIGHT CRANKCASE COVER INSTALLATION	7-20
CLUTCH SLAVE CYLINDER	7-8	GEARSHIFT LINKAGE	7-20

SERVICE INFORMATION

GENERAL

- This section covers removal and installation of the clutch hydraulic system, clutch, starter clutch and gearshift linkage.
- DOT-3 or 4 brake fluid is used for the hydraulic clutch and is referred to as clutch fluid in this section. Do not use other types of fluid as they are not compatible.
- Clutch maintenance can be done with the engine in the frame.
- Brake fluid will damage painted, plastic and rubber parts. Whenever handling brake fluid, protect the painted, plastic, and rubber parts by covering them with a rag. If fluid does get on these parts, wipe it off with a clean cloth.
- To keep slave cylinder piston from being forced out the cylinder, squeeze the clutch lever and tie it to handler grip.

SPECIFICATION

		STANDARD	SERVICE LIMIT
Clutch master cylinder	Cylinder I.D.	14.000–14.043 mm (0.5512–0.5528 in)	14.06 mm (0.554 in)
	Piston O.D.	13.957–13.984 mm (0.5495–0.5506 in)	13.94 mm (0.549 in)
Clutch slave cylinder	Cylinder I.D.	38.100–38.162 mm (1.5000–1.5024 in)	38.18 mm (1.503 in)
	Piston O.D.	38.036–38.075 mm (1.4975–1.4990 in)	38.02 mm (1.497 in)
Clutch	Outer guide I.D.	24.995–25.012 mm (0.9840–0.9847 in)	25.08 mm (0.987 in)
	Spring free length	35.500 mm (1.3976 in)	34.0 mm (1.34 in)
	Spring preload/length	22.4–24.8 kg/23.1 mm (49–59 lb/0.91 in)	—
	Disc thickness	3.72–3.88 mm (0.146–0.153 in)	3.5 mm (0.14 in)
	Plate warpage	—	0.30 mm (0.012 in)
Starter clutch	Driven gear O.D.	47.175–47.200 mm (1.8573–1.8583 in)	47.16 mm (1.857 in)

TORQUE VALUES

Clutch hose oil bolts	25–35 N·m (2.5–3.5 kg-m, 18–25 ft-lb)
Clutch lever pivot nut	5–7 N·m (0.5–0.7 kg-m, 4–5 ft-lb)
Starter clutch bolt	80–100 N·m (8.0–10.0 kg-m, 58–72 ft-lb)
Clutch center lock nut	62–68 N·m (6.2–6.8 kg-m, 45–49 ft-lb)
Starter clutch cover	26–30 N·m (2.6–3.0 kg-m, 19–22 ft-lb)
Oil pump driven sprocket bolt	15–20 N·m (1.5–2.0 kg-m, 11–14 ft-lb)

TOOLS**Special**

Snap ring pliers 07914—3230001 or equivalent in U.S.A.

Common

Extension bar 07716—0020500 or equivalent in U.S.A.

Lock nut wrench, 17 x 27 mm 07716—0020300

Clutch center holder 07724—0050001 or equivalent in U.S.A.

Gear holder 07724—0010100

TROUBLESHOOTING**Clutch lever action soft or spongy**

- Air bubbles in hydraulic system
- Low fluid level
- Hydraulic system leaking

Clutch lever action too hard

- Sticking piston(s)
- Clogged hydraulic system
- Lifter mechanism damaged

Clutch slips

- Hydraulic system sticking
- Discs worn
- Spring weak

Clutch will not disengage

- Air bubbles in hydraulic system
- Low fluid level
- Hydraulic system leaking
- Hydraulic system sticking
- Plates warped

Motorcycle creeps with clutch disengaged

- Air bubbles in hydraulic system
- Low fluid level
- Hydraulic system leaking
- Hydraulic system sticking
- Plates warped

Clutch operation feels rough

- Outer drum slots rough
- Sticking piston(s)

Gearshift Hard to shift

- Air bubbles in the clutch hydraulic system
- Shift spindle bent

CLUTCH FLUID REPLACEMENT/AIR BLEEDING

Check the fluid level with the fluid reservoir parallel to the ground.

CAUTION

- Do not remove the cover until the handlebar has been turned so that the reservoir is level.
- Avoid spilling fluid on painted, plastic, or rubber parts. Place a rag over these parts whenever the system is serviced.

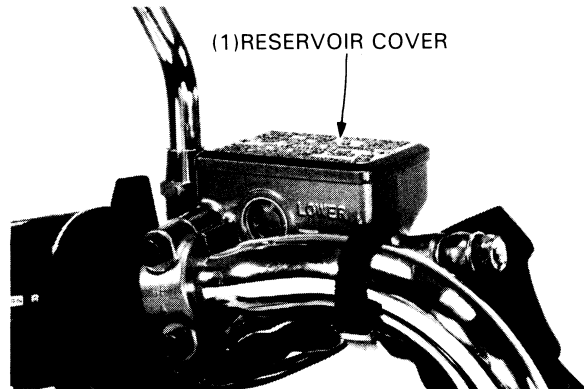

CLUTCH FLUID DRAINING

Remove the reservoir cover and diaphragm.
Connect a bleed hose to the bleed valve.
Loosen the slave cylinder bleed valve and pump the clutch lever.
Stop operating the lever when no fluid flows out of the bleed valve.

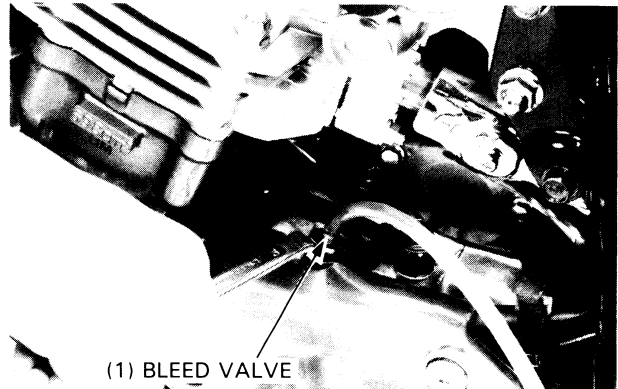

CLUTCH FLUID FILLING

Connect the mytyvac bleeder or equivalent to the bleed valve.
Pump the brake bleeder and loosen the bleed valve.
Add clutch fluid when the fluid level in the master cylinder reservoir is low.
Repeat above procedure until air bubbles do not appear in the bleed hose.

NOTE

- If air is entering the bleeder from around the bleed valve threads, seal the threads with teflon tape.
- Do not mix different types of fluid other than DOT 3 or DOT 4. They may not be compatible.

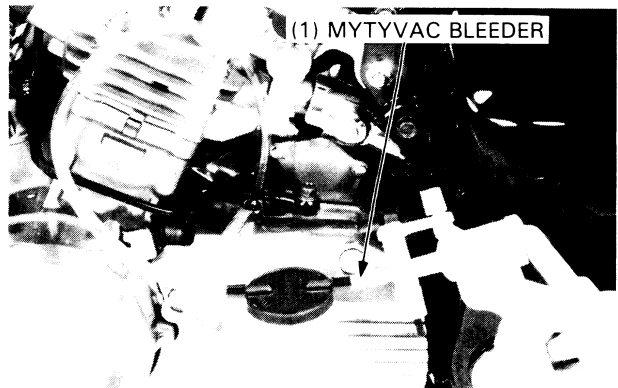

If the a mytyvac bleeder is not available, fill the system as follows:

Close the bleed valve, fill the reservoir, and install the diaphragm.
Pump up the system pressure with the lever until there are no air bubbles in the fluid flowing out of the reservoir small hole and lever resistance is felt.
Then bleed the system.

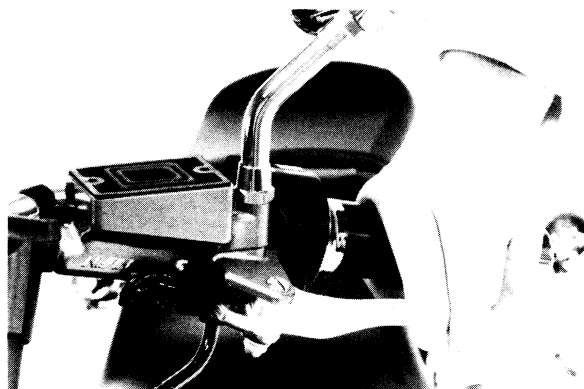

AIR BLEEDING

NOTE

- Check the clutch fluid level often while bleeding the clutch to prevent air from being pumped into the system.

- 1) Squeeze the clutch lever, open the bleed valve 1/2 turn then close the valve.

NOTE

- Do not release the clutch lever until the bleed valve has been closed.

- 2) Release the clutch lever slowly and wait several seconds after it is fully released, before repeating the procedure.

Repeat the above procedures until bubbles no longer appear at the end of the hose.
Tighten the bleed valve.

TORQUE: 4–7 N·m (40–70 kg-cm, 35–61 in-lb)

Fill the clutch fluid reservoir to the upper level.
Reinstall the reservoir cover and diaphragm.

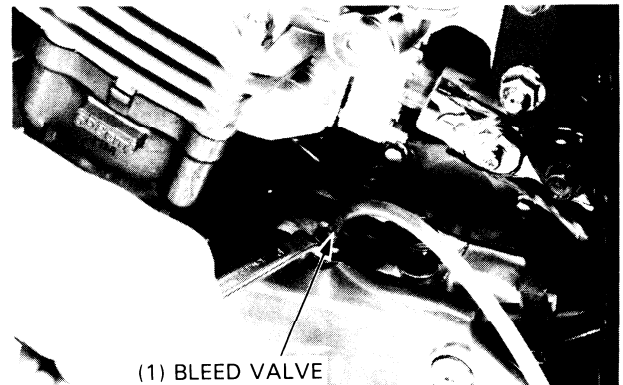
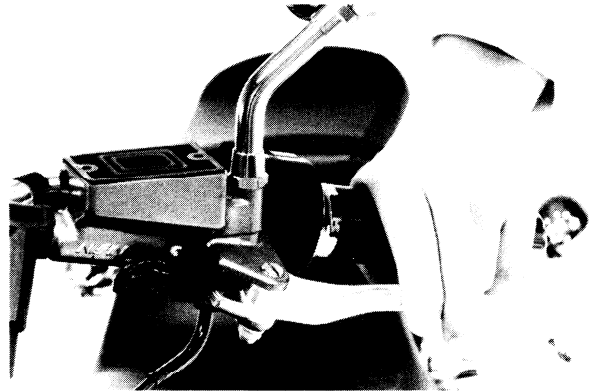

CLUTCH MASTER CYLINDER

REMOVAL

Drain the clutch fluid from the hydraulic system (page 7-4).
Remove the clutch upper oil bolt.
Remove the rear view mirror.
Disconnect the clutch switch wires.
Remove the master cylinder holder and clutch master cylinder.

CAUTION

- *Avoid spilling clutch fluid on painted surfaces. Place a rag over the fuel tank whenever the clutch system is serviced.*

NOTE

- When removing the oil bolt, cover the end of the hose to prevent contamination.

DISASSEMBLY

Remove the clutch lever and remove the clutch switch.

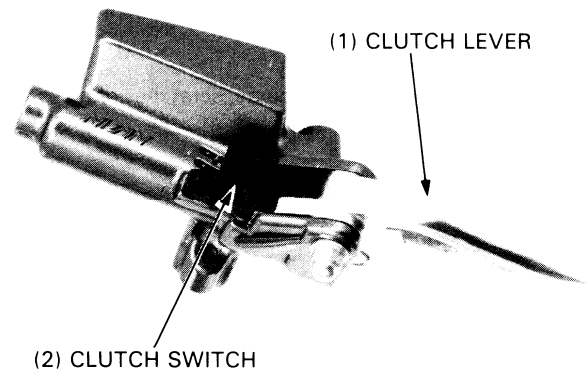
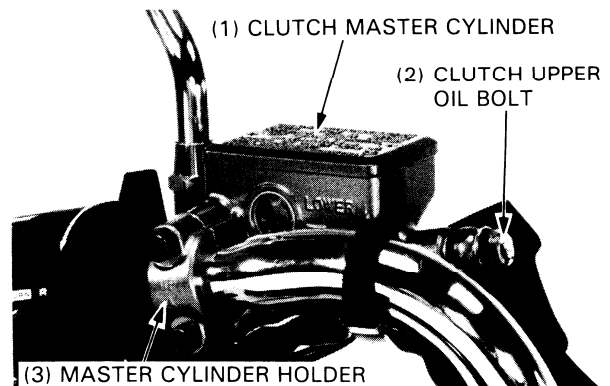

CLUTCH SYSTEM/GEARSHIFT LINKAGE

Remove the push rod and boot.

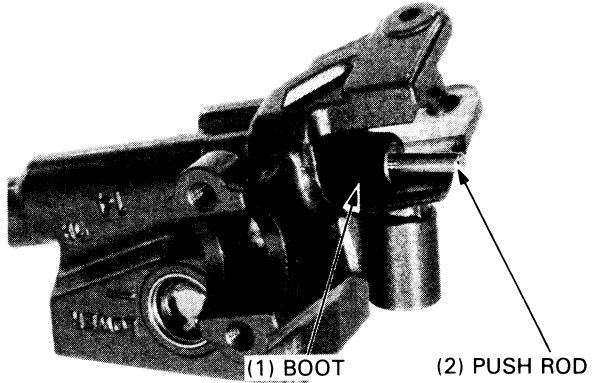

Remove the circlip from the master cylinder body.

TOOL:
SNAPRING PLIERS

**07914-3230001 or
EQUIVALENT TOOL COM-
MERCIALY AVAILABLE**

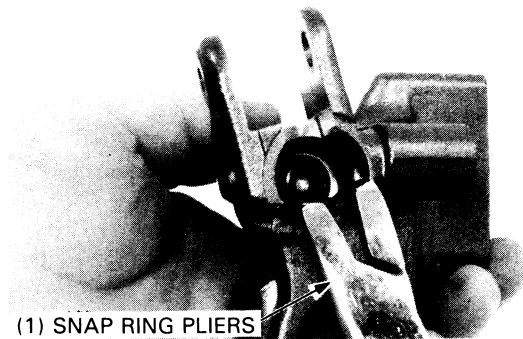

Remove the washer, piston and spring from the master cylinder body.
Check the primary cup and secondary cup for wear, damage or deterioration.

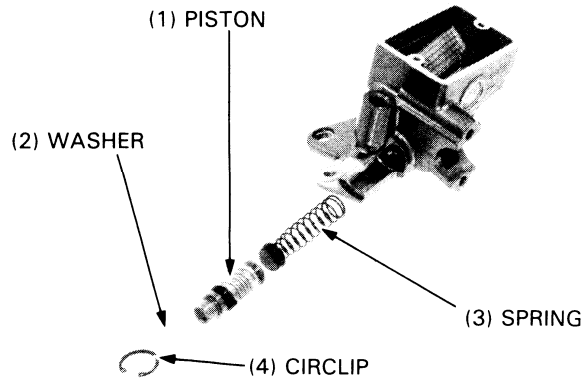

INSPECTION

Master Cylinder I.D.

Check the master cylinder for scores, scratches or nicks. Measure the master cylinder I.D.

SERVICE LIMIT: 14.06 mm (0.554 in)

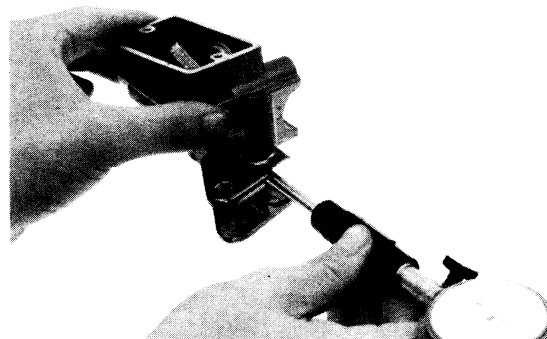

CLUTCH SYSTEM/GEARSHIFT LINKAGE

Master Piston O.D.
Measure the master piston O.D.

SERVICE LIMIT: 13.94 mm (0.549 in)

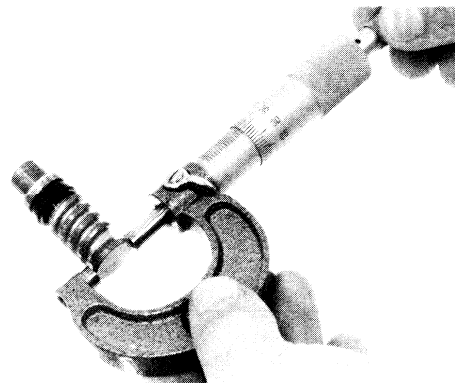

ASSEMBLY

CAUTION

- Handle the master piston, primary cup and secondary cup as a set.

Coat all parts with clean clutch fluid before assembly.
Install the spring, primary cup and piston.

CAUTION

- When installing the cups, do not allow the lips to turn inside out.

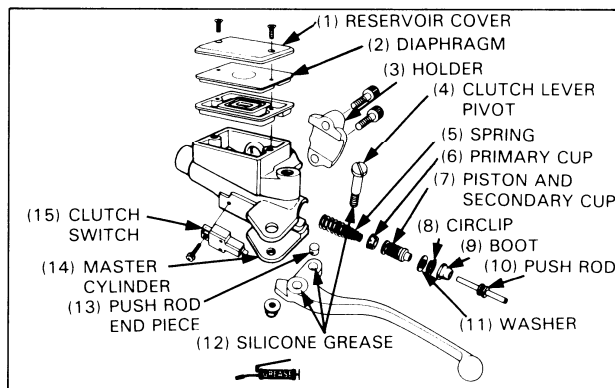

Install the washer and the circlip, making sure circlip is seated firmly in the groove.
Install the boot and push rod.

TOOL:
SNAPRING PLIERS

**07914-3230001 or
EQUIVALENT TOOL COM-
MERCIALY AVAILABLE**

Install the clutch switch.
Install the push rod end piece into the clutch lever hole and install the clutch lever.

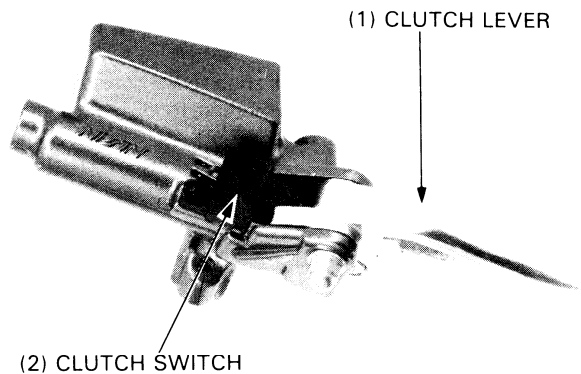

INSTALLATION

Place the master cylinder on the handlebar and install the holder with the "UP" mark facing up and insert the two mounting bolts.

Align the holder mating surface with the handlebar punch mark.

Tighten the top bolt first, then the bottom bolt.

Install the oil hose with the bolt and its two sealing washers.

TORQUE: 25-35 N·m (2.5-3.5 kg-m, 18-25 ft-lb)

Connect the clutch switch wires to the switch terminals.
Fill the reservoir and bleed the clutch system (page 7-4).

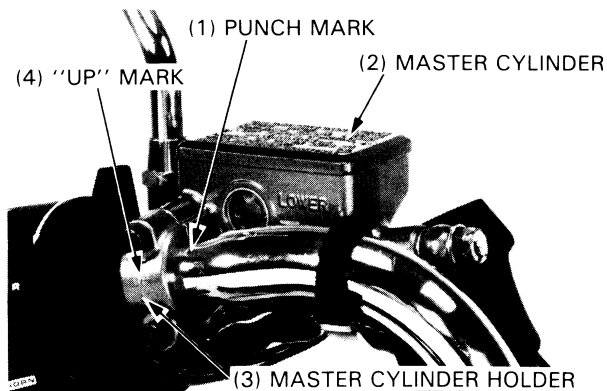

CLUTCH SLAVE CYLINDER

REMOVAL

Remove the rear cover.
Remove the clutch oil bolt and drain the clutch fluid from the clutch system.

NOTE

- Avoid spilling clutch fluid on painted surfaces.

Remove the clutch slave cylinder mounting bolts and clutch slave cylinder.

Remove the gasket and dowel pins.

Remove the clutch lifter rod.

Remove the piston from the cylinder.

If piston removal is hard, place a shop towel over the piston to cushion the piston it is expelled, and position the cylinder with the piston down.

Apply compressed air to the fluid inlet to remove the piston.
Use the air in short spurts.

Remove the spring from the piston.

Remove the oil and piston seals.
Clean the piston groove with clutch fluid.
Check the piston spring for weakness or damage.

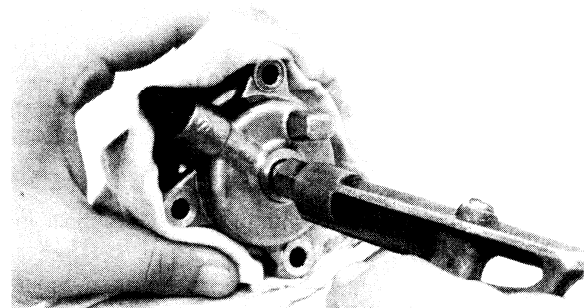
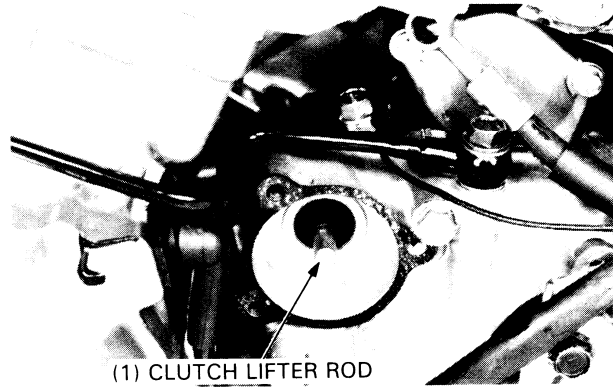
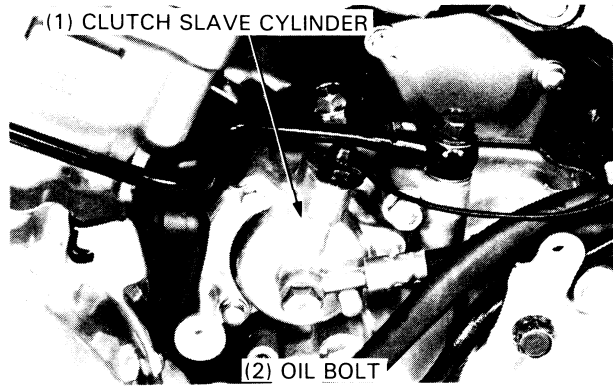

(1) PISTON SEAL

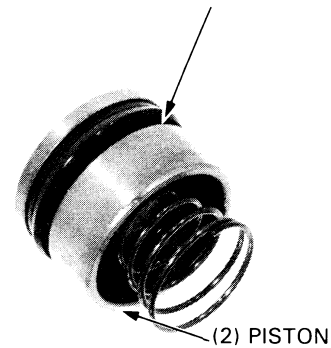

INSPECTION

Piston O.D.

Check the piston for scoring or scratches.
Measure the outside diameter of the piston with a micrometer.

SERVICE LIMIT: 38.02 mm (1.497 in)

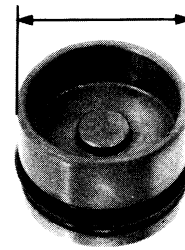

Cylinder I.D.

Check the slave cylinder for scoring or scratches.
Measure the inside diameter of the cylinder bore.

SERVICE LIMIT: 38.18 mm (1.503 in)

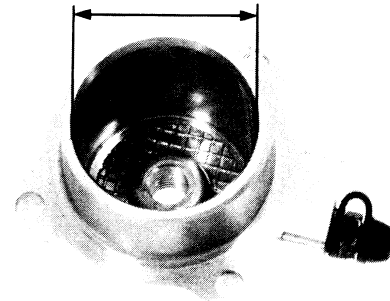

ASSEMBLY

Assemble the slave cylinder in the reverse order of disassembly.

The oil and piston seals must be replaced with new ones whenever they have been removed.

Lubricate the piston and piston seal with a medium grade of Hi-Temperature silicone grease or brake fluid before assembly.

Be certain the piston seal is seated in the piston groove.
Place the piston in the cylinder with the seal end facing out.

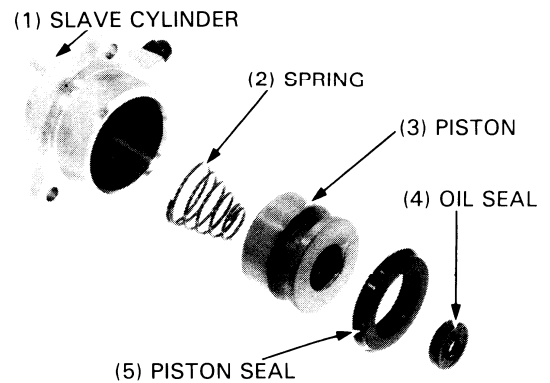

INSTALLATION

Install the clutch lifter rod with its indented end (gold anodized side) facing the slave cylinder.

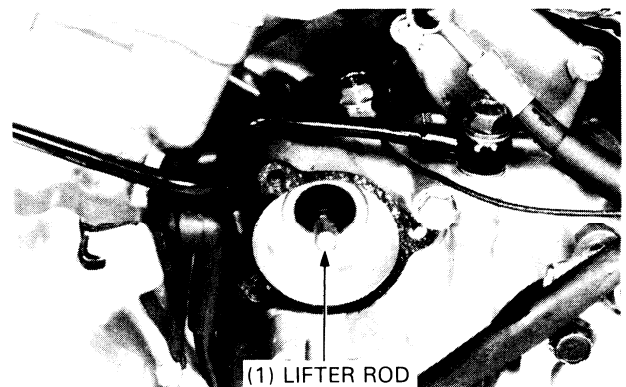

CLUTCH SYSTEM/GEARSHIFT LINKAGE

Install the slave cylinder.
Connect the clutch hose with the oil bolt and the two sealing washers.

TORQUE: 25–35 N·m (2.5–3.5 kg·m, 18–25 ft·lb)

Fill the clutch fluid reservoir and bleed the clutch system (page 7-4).

Install the rear cover.

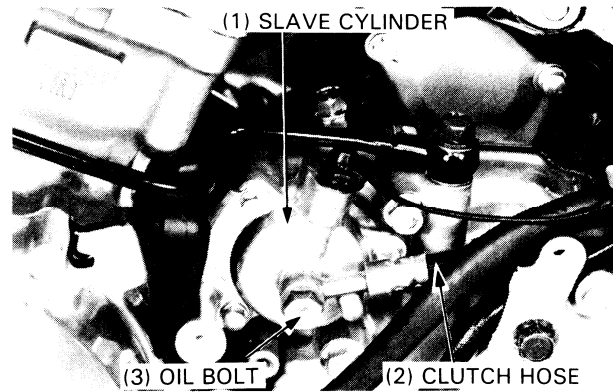

RIGHT CRANKCASE COVER REMOVAL

Drain the engine oil.
Remove the right foot peg.

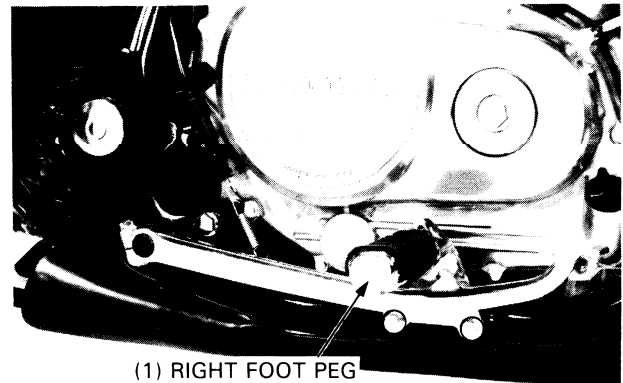

Remove the spring from the brake light switch.
Remove the bolts and right crankcase cover.



Remove the gasket and dowel pins.

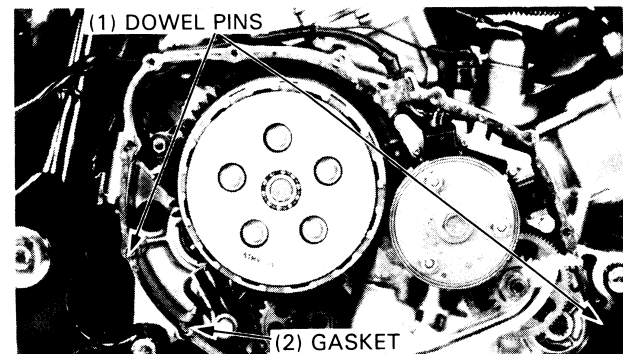

STARTER CLUTCH

REMOVAL

TOOL:

GEAR HOLDER 07724-0010100

Remove the starter clutch bolt.
 Set the gear holder between the primary driven gear and sub gear.
 Remove the starter clutch assembly.
 Remove the thrust washer.

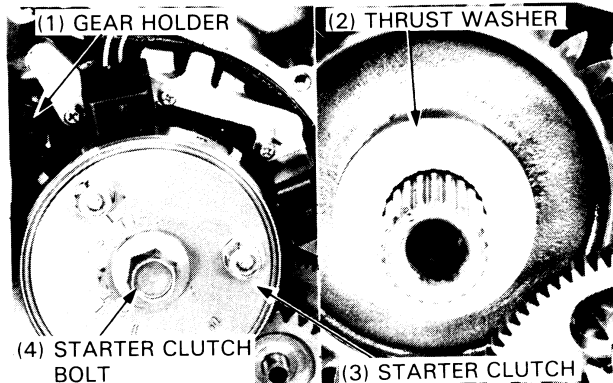

Remove the starter idle gear and idle gear shaft.

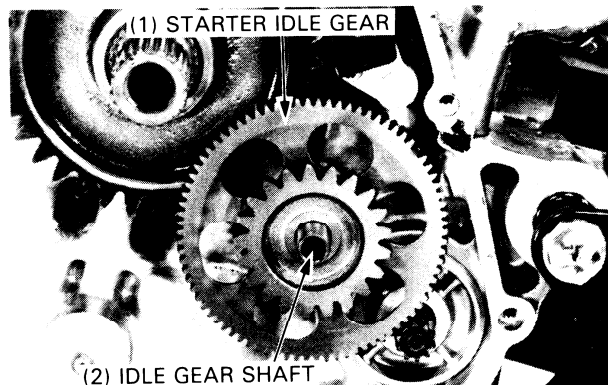

Remove the primary drive gear.

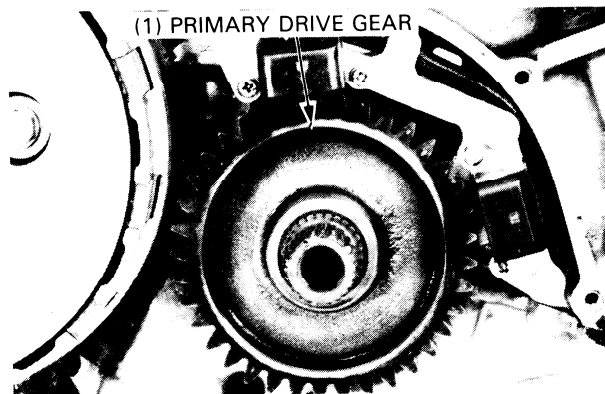

DISASSEMBLY

Check the operation of one-way clutch.
 The starter driven gear should not turn counterclockwise. It should only turn clockwise.
 Remove the starter driven gear and needle bearing from the starter clutch.
 Inspect the rollers for smooth operation.
 Remove the starter clutch cover by removing the three bolts.
 Remove the clutch rollers, plungers and springs.

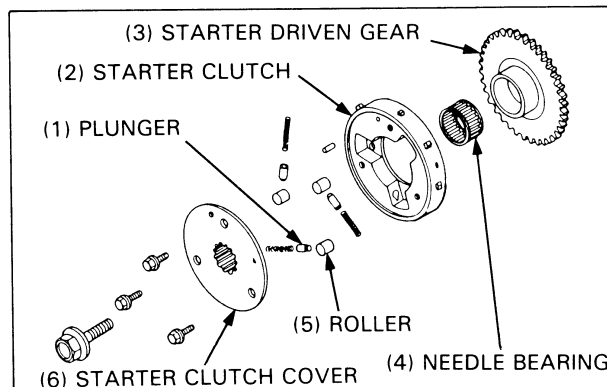

CLUTCH SYSTEM/GEARSHIFT LINKAGE

INSPECTION

Check the rollers for excessive wear, and the springs for weakness or damage.
Check the plunger for wear.

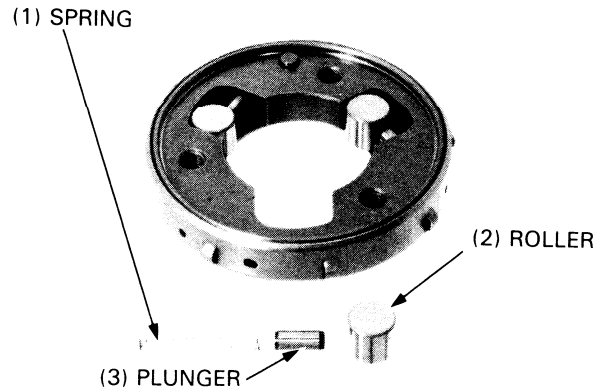

Inspect the driven gear for damage or excessive wear.
Measure the driven gear O.D.

SERVICE LIMIT: 47.16 mm (1.857 in)

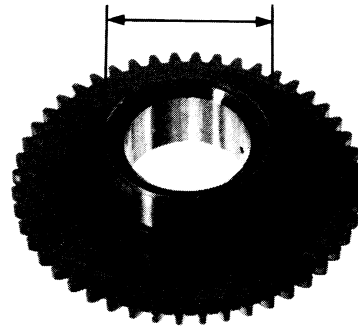

ASSEMBLY

Install the springs, plungers and rollers into the starter clutch.

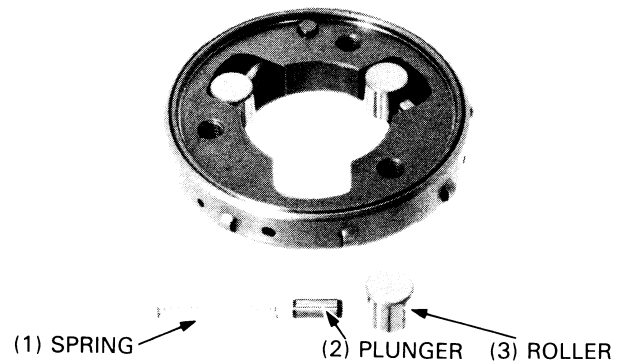

Install the dowel pin.
Install the starter clutch cover aligning the dowel pin hole with the dowel pin.

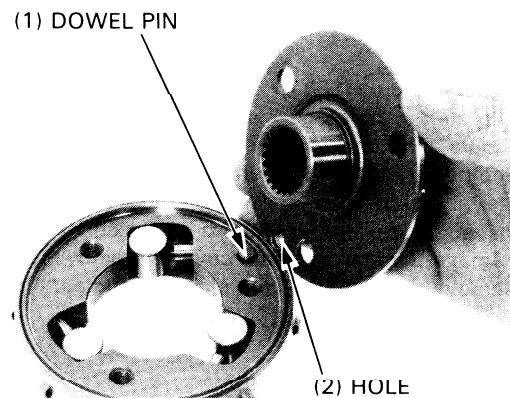

CLUTCH SYSTEM/GEARSHIFT LINKAGE

Install the clutch cover and tighten the three cover bolts.

TORQUE: 26–30 N·m (2.6–3.0 kg-m, 19–22 ft-lb)

NOTE

- Apply a locking agent to the bolt threads.

(1) CLUTCH COVER

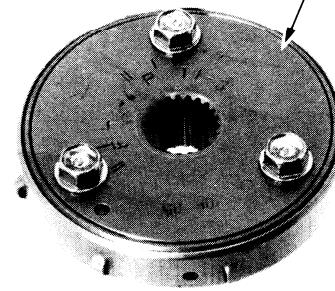

Install the needle bearing and the starter driven gear by turning it clockwise.

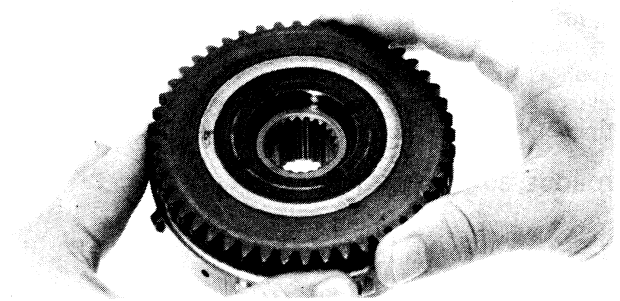

INSTALLATION

Install the primary drive gear onto the crankshaft while moving the primary driven sub gear with a screw driver.

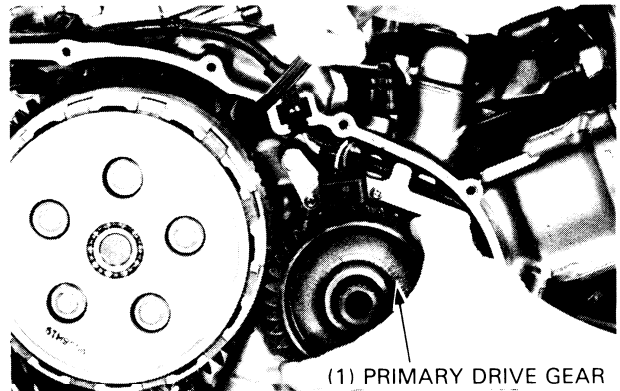

Install the starter idle gear and shaft.
Install the thrust washer onto the crankshaft.

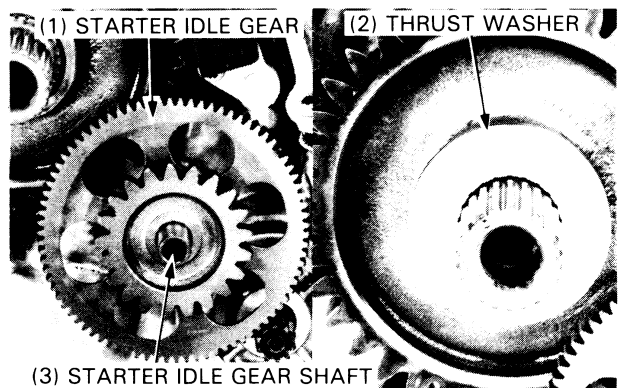

CLUTCH SYSTEM/GEARSHIFT LINKAGE

Align the punch marks on the starter clutch and crankshaft and install the starter clutch.

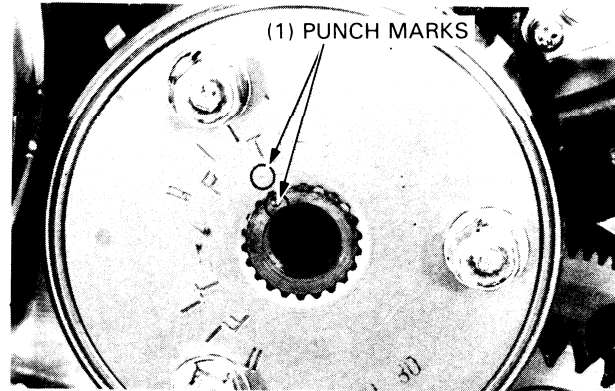

Hold the flywheel with the gear holder.

TOOL:

GEAR HOLDER 07724-0010100

Apply a locking agent to the threads of the primary driven gear bolt.

Tighten the starter clutch bolt.

TORQUE: 80–100 N·m (8.0–10.0 kg-m, 58–72 ft-lb)

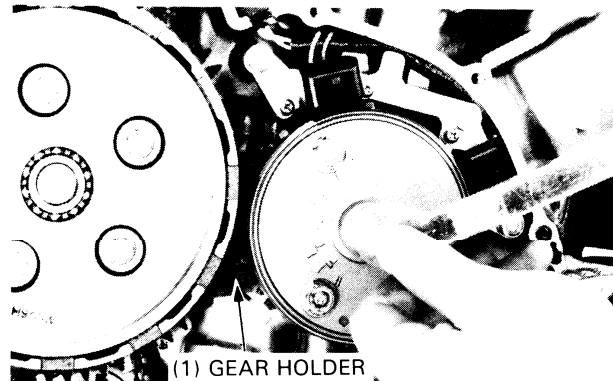

CLUTCH

REMOVAL

Remove the following:

- right crankcase cover (page 7-10).
- gasket and dowel pins.
- starter idle gear.
- starter clutch (page 7-11).

CAUTION

- *To prevent the clutch system from air contamination, slowly squeeze the clutch lever immediately after removing the clutch pressure plate, and tie the lever to the handlebar grip.*

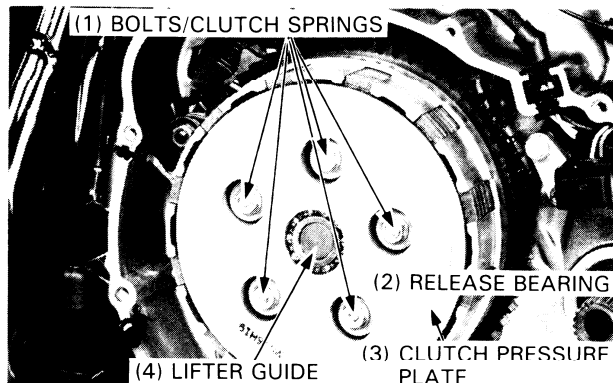

Remove the bolts and clutch springs.

NOTE

- Loosen the bolts in crisscross pattern in 2–3 steps.

Remove the clutch pressure plate with the lifter guide and release bearing.

Remove the clutch lifter rod, clutch plates and discs.

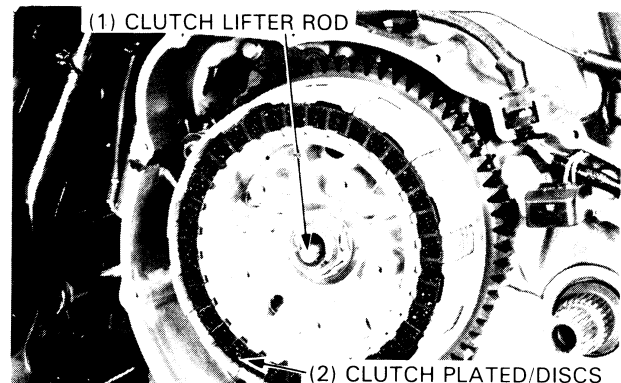

CLUTCH SYSTEM/GEARSHIFT LINKAGE

Bend the lock washer claws out securely around the nut.



Hold the clutch center with a clutch center holder and remove the lock nut and lock washer.

TOOLS:

CLUTCH CENTER HOLDER

07724-0050001 or
EQUIVALENT COM-
MERCIALY AVAILABLE
IN U.S.A.

LOCK NUT WRENCH, 17 x 27 mm 00716-002030

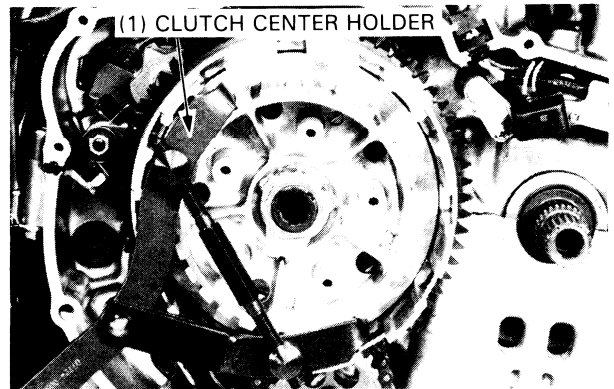

Remove the thrust washer, clutch center and clutch outer.

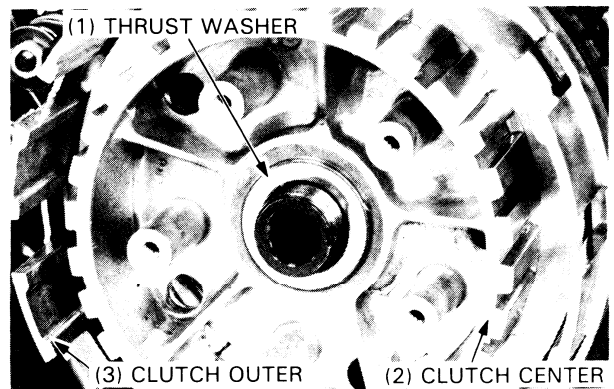

Remove the oil pump driven sprocket bolt and washer.

Remove the oil pump sprockets and oil pump drive chain.
Remove the clutch outer guide, washer and collar from the mainshaft.

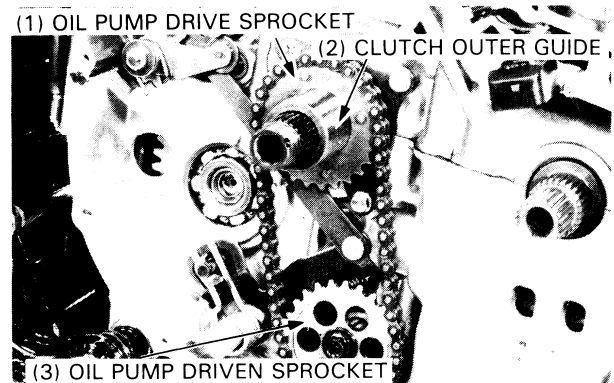

CLUTCH SYSTEM/GEARSHIFT LINKAGE

INSPECTION

Clutch Spring

Measure the clutch spring free length.

SERVICE LIMIT: 34.0 mm (1.34 in)

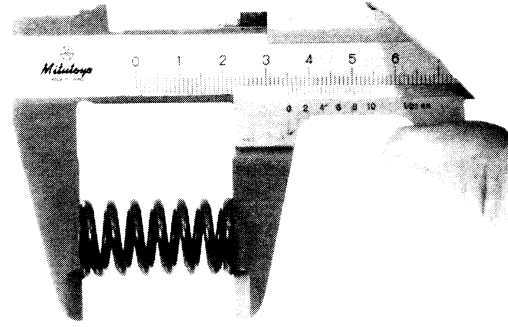

Clutch Disc

Replace the clutch discs if they show signs of scoring or wear.
Measure the thickness of each disc.

SERVICE LIMIT: 3.5 mm (0.14 in)

Replace any disc that is thinner than the service limit.

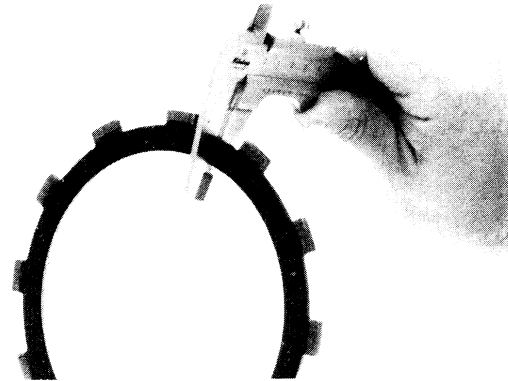

Clutch Plate

Check for plate warpage on a surface plate, using a feeler gauge.

SERVICE LIMIT: 0.30 mm (0.012 in)

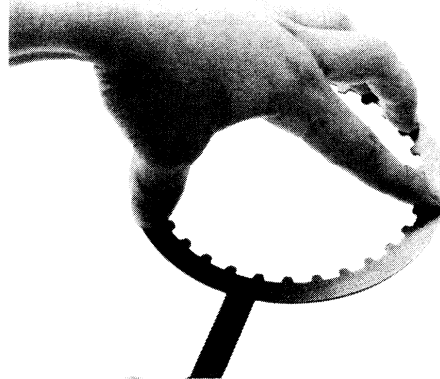

Clutch Outer Guide

Measure the I.D. of the clutch outer guide.

SERVICE LIMIT: 25.08 mm (0.987 in)

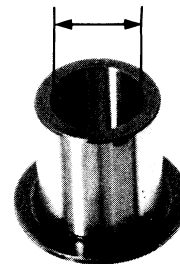

Clutch Outer

Check the slots in the clutch outer for nicks, cuts or indentations made by the friction discs.

Check the clutch outer needle bearing for damage or excessive play.

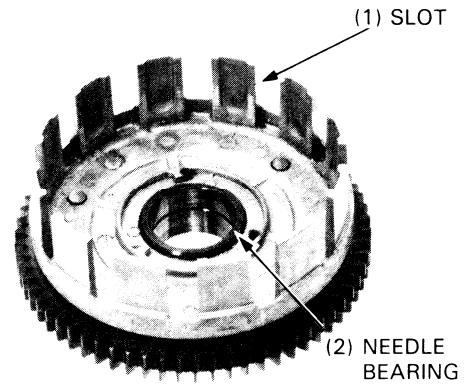

INSTALLATION

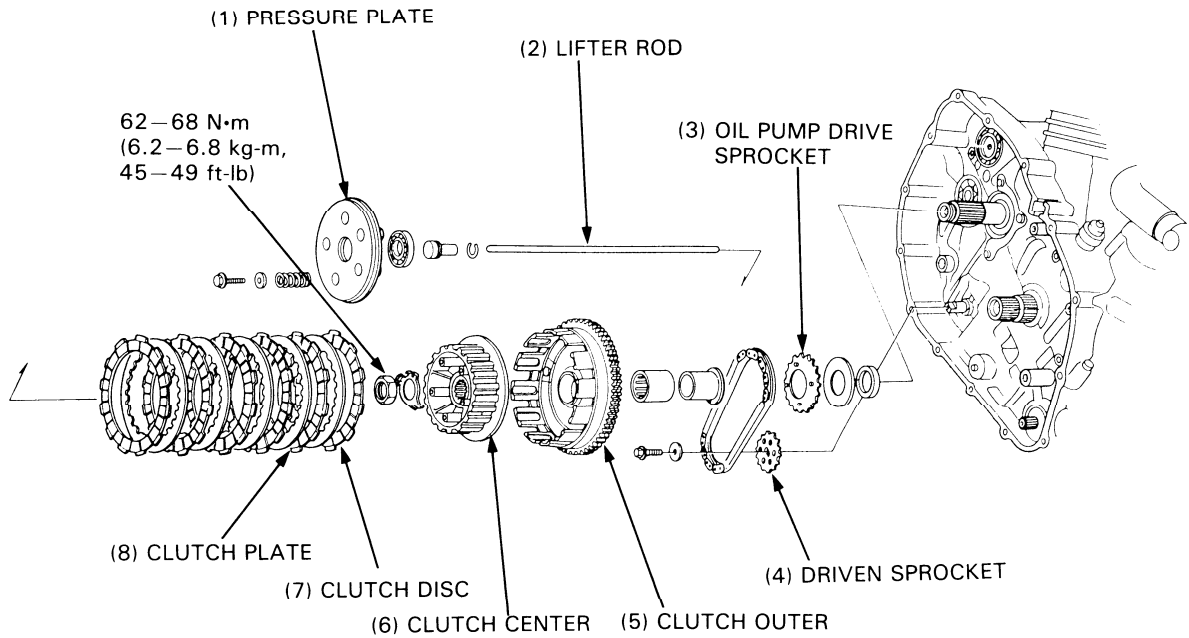

Install the collar, washer and clutch outer guide.
 Install the oil pump drive sprocket with the pins facing out side.
 Install the pump drive chain and driven sprocket.
 Tighten the oil pump driven sprocket bolt and washer.

TORQUE: 15–20 N·m (1.5–2.0 kg-m, 11–14 ft-lb)

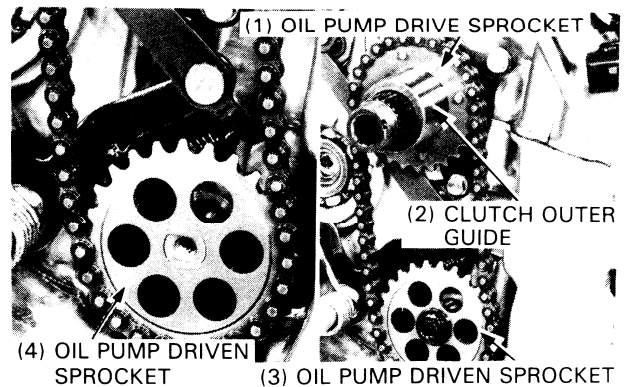

CLUTCH SYSTEM/GEARSHIFT LINKAGE

Install the clutch outer onto the mainshaft, aligning the holes in the clutch outer with the pins on the oil pump drive sprocket.

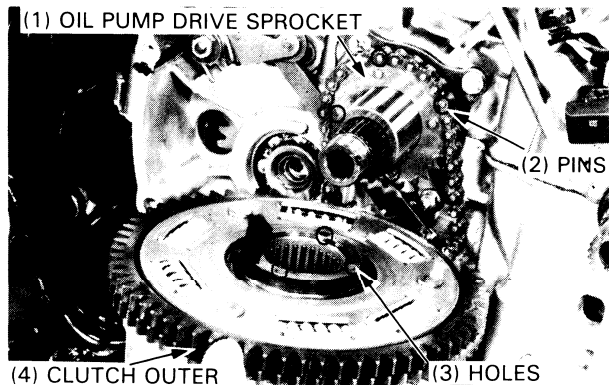

Install the clutch center and thrust washer.



Install the lock washer.
Install the clutch center holder to hold the clutch center.
Tighten the lock nut.

TORQUE: 62–68 N·m (6.2–6.8 kg-m, 45–49 ft-lb)

Bend the lock washer claws out securely around the nut.

TOOL:
CLUTCH CENTER HOLDER 07724–0050001 or
EQUIVALENT COMMERCIAL-
LY AVAILABLE IN U.S.A.



Coat the 6 discs and 5 plates with clean engine oil and install them as shown.

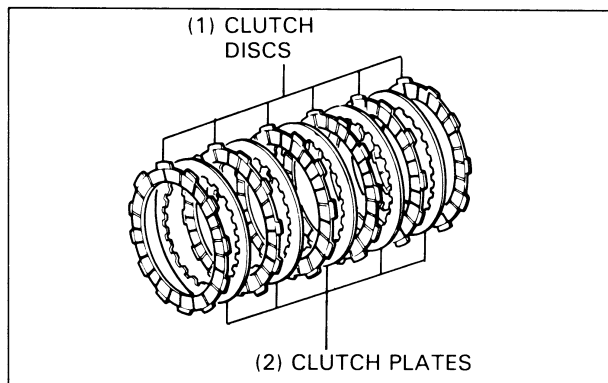

CLUTCH SYSTEM/GEARSHIFT LINKAGE

Install the lifter rod into the mainshaft.

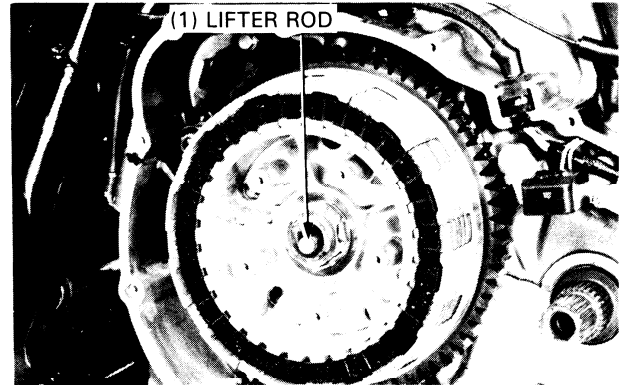

Make sure that the circlip is in place.

Install the release bearing and lifter guide into the clutch pressure plate.
Install the clutch pressure plate.

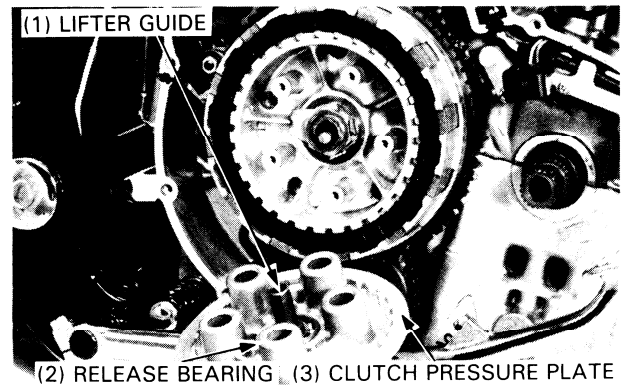

Install the springs.

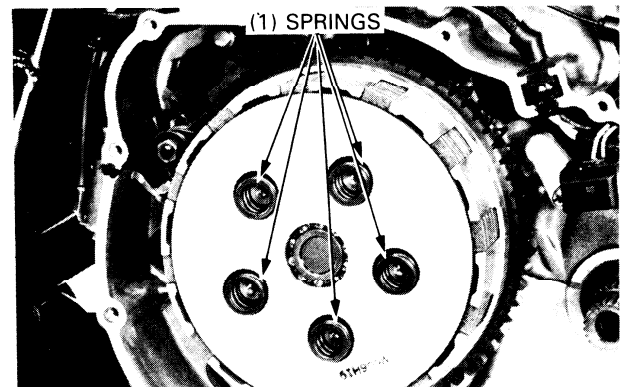

Install and tighten the bolts in a crisscross pattern in 2–3 steps.

Release the clutch lever by removing the tie holding it on the handlebar grip before tightening the clutch bolts.

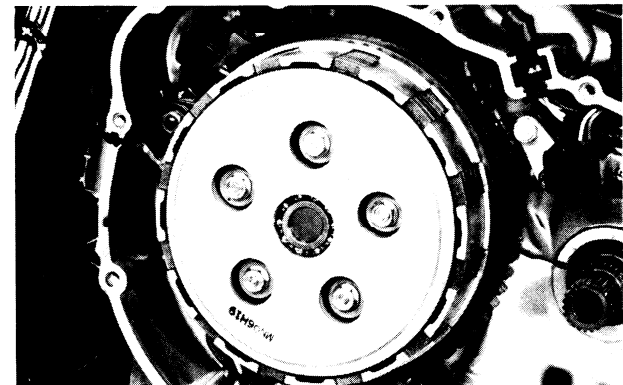

CLUTCH SYSTEM/GEARSHIFT LINKAGE

RIGHT CRANKCASE COVER INSTALLATION

Install the new gasket and the dowel pins.

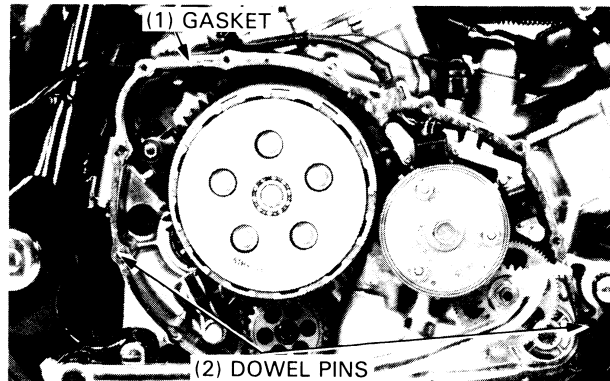

Install the right crankcase cover and tighten the bolts in a crisscross pattern.

Fill the crankcase with the recommended oil (page 2-1).

Install the right foot ped and brake light switch spring.

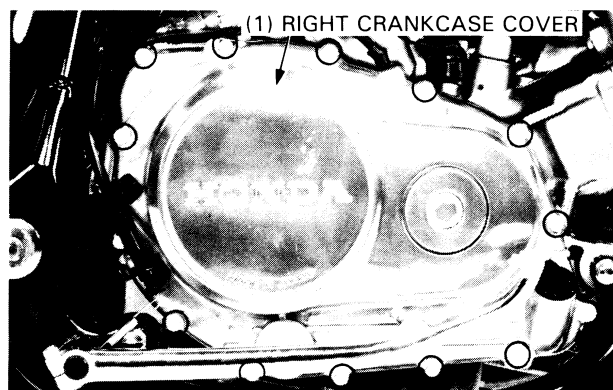

GEARSHIFT LINKAGE

REMOVAL

Drain the engine oil.

Remove the following:

- right crankcase cover
- starter clutch
- clutch
- oil pump drive chain, drive and driven sprocket.

Remove the gearshift arm from the gearshift spindle.

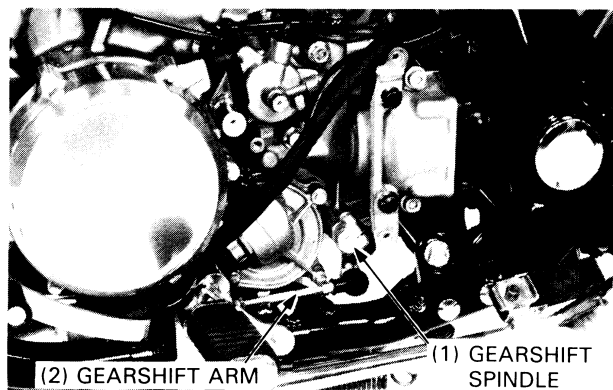

Remove the drum stopper arm nut, washer, collar, spring, drum stopper arm and stopper plate.

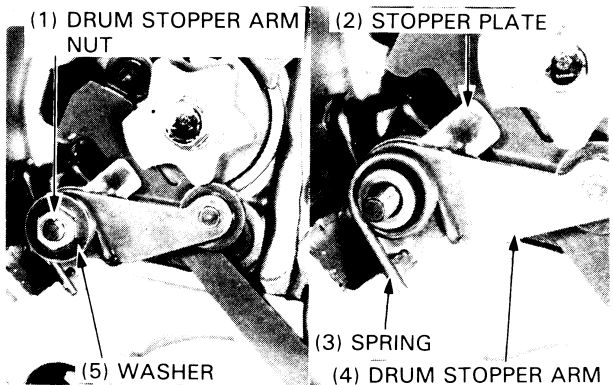

Pull the gearshift spindle assembly out of the crankcase.

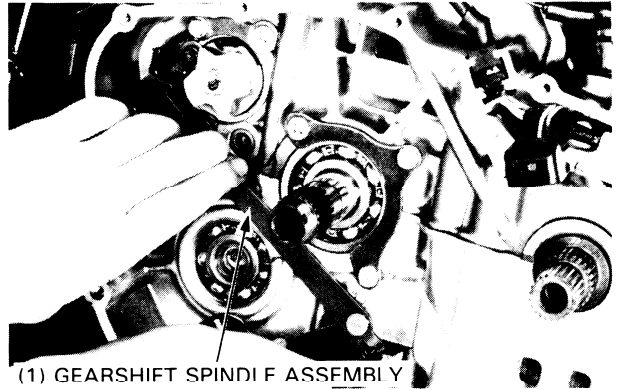

Remove the neutral stopper arm bolt, neutral stopper arm and spring.
Remove the cam plate bolt and cam plate assembly.

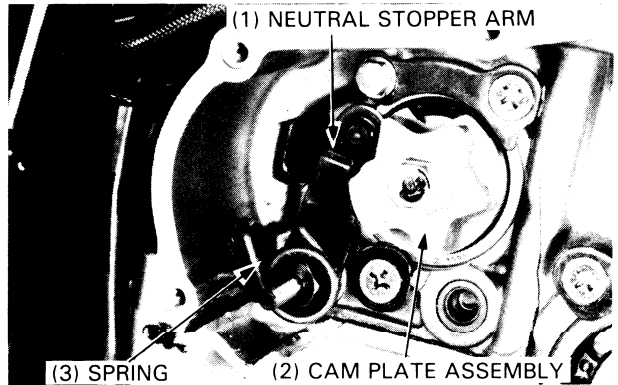

INSTALLATION

Install the washer, neutral stopper arm, spring and neutral stopper arm bolt.
Tighten the neutral stopper arm bolt securely.

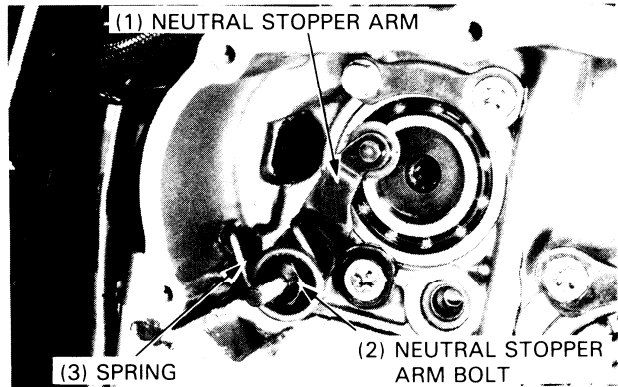

Install the dowel pin in the hole of the shift drum.
Insert the five pins in the holes of the cam plate.
Align the cam plate hole with the dowel pin on the shift drum and install the cam plate.
Tighten the bolts securely.

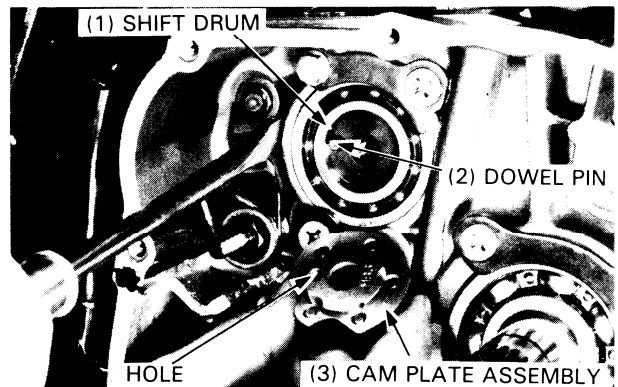

CLUTCH SYSTEM/GEARSHIFT LINKAGE

Install the gearshift spindle assembly into the hole of the crankcase.

Slip the ends of the return spring over the stopper pin.

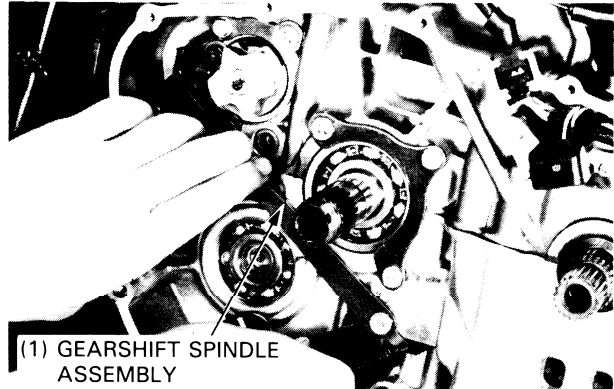

Install the stopper plate by aligning the groove with the crankcase as shown.



Install the shift drum stopper arm, collar and spring. Hook the end of the spring on lug in the crankcase.

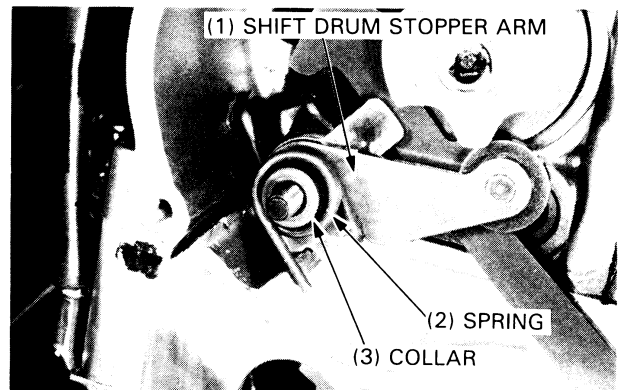

Install the washer and drum stopper arm nut. Tighten the drum stopper arm nut. Rotate the gearshift spindle and check the gearshift linkage for smooth operation.

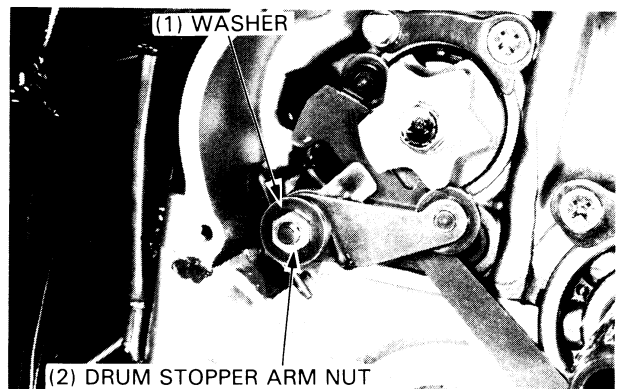

CLUTCH SYSTEM/GEARSHIFT LINKAGE

Install the following parts:

- clutch (page 7-13)
- starter clutch (page 7-17)
- R. crankcase cover (page 7-20)

Align the punch marks on the gearshift and gearshift spindle and install the gearshift arm.

Check the gearshift linkage for smooth operation.

