

2. LUBRICATION

SERVICE INFORMATION	2-1	PRESSURE RELIEF VALVE	2-6
TROUBLESHOOTING	2-2	OIL PUMP	2-7
ENGINE OIL LEVEL	2-3	FINAL DRIVE OIL	2-11
ENGINE OIL & FILTER CHANGE	2-3	LUBRICATION POINTS	2-12
OIL PRESSURE CHECK	2-4	CONTROL CABLE LUBRICATION	2-12
OIL STRAINER CLEANING	2-5		

SERVICE INFORMATION

SPECIFICATIONS

Engine oil

Oil capacity	2.9 liter (3.1 U.S. qt., 2.5 Imp qt) after draining 3.0 liter (3.2 U.S. qt., 2.6 Imp qt) after disassembly
Oil recommendation	Use Honda 4-Stroke Oil or equivalent. API Service Classification: SE or SF. Viscosity: SAE 10W-40 Other viscosities shown in the chart may be used when the average temperature in your riding area is within the indicated range.
<div style="text-align: right;"> <p>OIL VISCOSITIES</p> <p>SAE 20W-50: 0 to 100 °F (-20 to 40 °C)</p> <p>SAE 20W-40: 0 to 100 °F (-20 to 40 °C)</p> <p>SAE 10W-40: 0 to 100 °F (-20 to 40 °C)</p> <p>SAE 10W-30: 0 to 80 °F (-20 to 30 °C)</p> </div>	
Oil pressure (at oil pressure switch)	450±80 kPa (4.5±0.8 kg/cm ² , 64±11 psi) at 6,000 rpm (80°C/176°F)
Oil pump delivery	41 liter (43.3 U.S. qt)/min. at 5,900 rpm

Oil pump service data

	STANDARD	SERVICE LIMIT
Rotor tip clearance	0.15 mm (0.006 in)	0.20 mm (0.008 in)
Pump body clearance	0.15—0.22 mm (0.006—0.009 in)	0.35 mm (0.014 in)
Pump end clearance	0.02—0.07 mm (0.001—0.003 in)	0.10 mm (0.004 in)

Final drive gear

Oil capacity	150 cc (5.1 oz.) after disassembly 130 cc (4.4 oz.) after draining
Recommended oil	Hypoid gear oil: SAE #80

LUBRICATION

TORQUE VALUES

Crankcase drain plug	35–40 N·m (3.5–4.0 kg-m, 25–29 ft-lb)
Cylinder drain plug	10–14 N·m (1.0–1.4 kg-m, 7–10 ft-lb)
Engine oil filter	15–20 N·m (1.5–2.0 kg-m, 11–14 ft-lb)
Oil pressure switch	10–14 N·m (1.0–1.4 kg-m, 7–10 ft-lb) Apply 3-BOND sealant or equivalent to the bolt threads.
Oil pump driven sprocket bolt	15–20 N·m (1.5–2.0 kg-m, 11–14 ft-lb)
Final drive gear drain bolt	10–14 N·m (1.0–1.4 kg-m, 7–10 ft-lb)

TOOLS

Special	
Oil pressure gauge	07506–3000000
Oil pressure gauge attachment	07510–4220100
Oil filter wrench	07912–6110001

} or Equivalent commercially available

TROUBLESHOOTING

Oil level too low

- Oil level not replenished frequently enough
- External oil leaks
- Worn piston rings
- Worn valve guide or seal

Oil contamination

- Oil or filter not changed often enough
- Head gasket faulty
- Worn piston rings
- Oil emulsification
- Radiator coolant contamination
 - Blown cylinder head gasket
 - Leaky coolant passage
- Water contamination

Low oil pressure

- Oil level low
- Pressure relief valve stuck open
- Plugged oil pick-up screen or oil filter
- Oil pump worn
- External oil leaks
- Incorrect oil being used

High oil pressure

- Pressure relief valve stuck closed
- Plugged oil filter, gallery, or metering orifice
- Incorrect oil being used

No oil pressure

- Oil level low; no oil
- Oil pump drive chain broken
- Oil pump faulty
- Internal oil leakage
- Broken oil pump drive shaft

Oil pressure warning indicator stays on

- Faulty oil pressure switch.
- Short circuit in indicator wire
- Low or no oil pressure

ENGINE OIL LEVEL

Start the engine and let it idle for 2–3 minutes. Turn off the engine. Support the motorcycle in an upright position on level ground.

Remove the filler cap/dipstick, wipe it clean and insert it without screwing it in. Remove the filler cap/dipstick and check the oil level.

If the level is below the lower level mark on the dipstick, fill to the upper level mark with the recommended oil (page 2-1).

Check the oil pressure with the oil pressure warning light after the engine starts. The light should go off after one or two seconds.

If it does not, stop the engine and do the oil pressure check on page 2-4. If the pressure check is OK, replace the pressure switch.

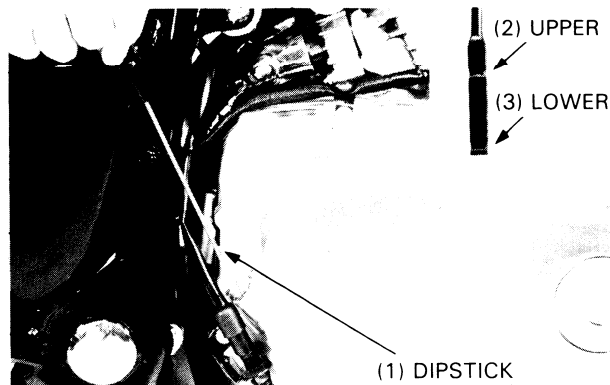

ENGINE OIL & FILTER CHANGE

NOTE

- Change engine oil with the engine warm and support the motorcycle on level ground to assure complete and rapid draining.

Stop the engine.

Remove the dipstick, cylinder head side drain plug, crankcase side drain plug and drain the engine oil.

Check that the sealing washers on the drain plug are in good condition and reinstall them.

TORQUE:

Crankcase drain plug:

35–40 N·m (3.5–4.0 kg-m, 25–29 ft-lb)

Cylinder drain plug:

10–14 N·m (1.0–1.4 kg-m, 7–10 ft-lb)

Remove the oil filter with a filter wrench and let the remaining oil drain out. Discard the oil filter.

TOOL:

Oil filter wrench

07912–6110001

Replace the oil filter with a new one.

Coat the filter O-ring with clean engine oil before installing the filter.

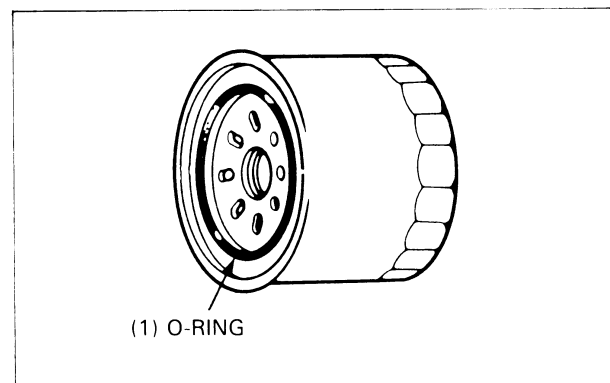
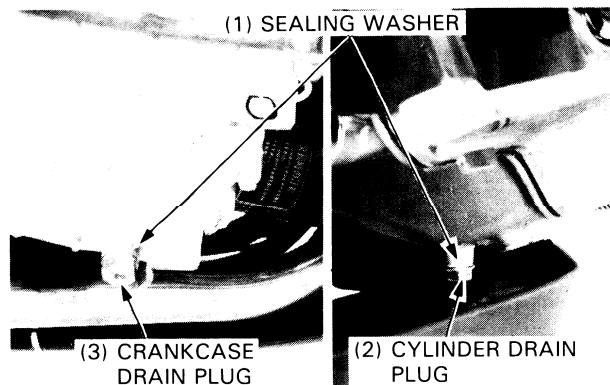

LUBRICATION

Install and tighten the oil filter.

TORQUE: 15–20 N·m (1.5–2.0 kg-m, 11–14 ft-lb)

TOOL:

OIL FILTER WRENCH 07912–611001

Fill the crankcase with 2.9 liters (3.1 US qt, 2.5 Imp qt) of the recommended oil (page 2-1). Reinstall the oil filler cap/dipstick.

Start the engine and let it idle for 2–3 minutes, then stop the engine.

Make sure that the oil level is at the upper level mark on the dipstick.

Make sure that there are no oil leaks.

Install the lower fairing.

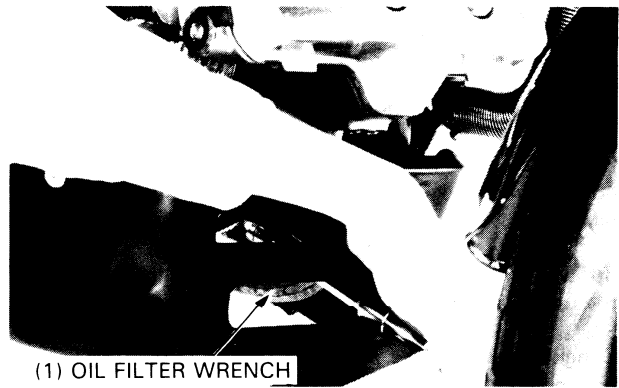

OIL PRESSURE CHECK

NOTE

- If the oil pressure indicator light remains on a few seconds, check the indicator system, before checking the oil pressure.

Warm the engine up to normal operating temperature (approximately 80°C/176°F).

Check the oil level.

Stop the engine and disconnect the oil pressure switch wire.

Remove the oil pressure switch.

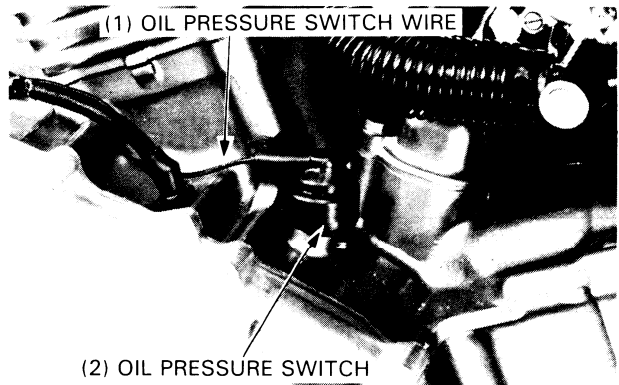

Install the oil pressure gauge attachment and connect an oil pressure gauge.

TOOLS:

OIL PRESSURE GAUGE 07506–300000 or EQUIVALENT COMMERCIALLY AVAILABLE IN U.S.A.

OIL PRESSURE GAUGE ATTACHMENT 07510–4420100 or EQUIVALENT COMMERCIALLY AVAILABLE IN U.S.A.

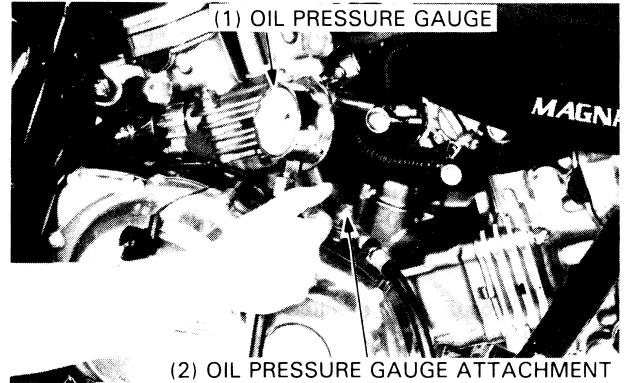

Start the engine and check the oil pressure at 5,000 rpm.

OIL PRESSURE:

450 ± 80 kPa (4.5 ± 0.8 kg/cm², 64 ± 11 psi) at 6,000 rpm (80°C/176°F)

TOOL:

OIL PRESSURE GAUGE ATTACHMENT 07510–4220100

Stop the engine.

Apply 3-BOND® sealant or equivalent to the pressure switch threads and install.

TORQUE: 10–14 N·m (1.0–1.4 kg-m, 7–10 ft-lb)

CAUTION

- To prevent crankcase damage, do not overtighten the switch.

Connect the oil pressure switch wire.

Start the engine.

Check that the oil pressure warning indicator goes out in one or two seconds.

If the oil pressure warning indicator stays on, stop the engine immediately and determine the cause.

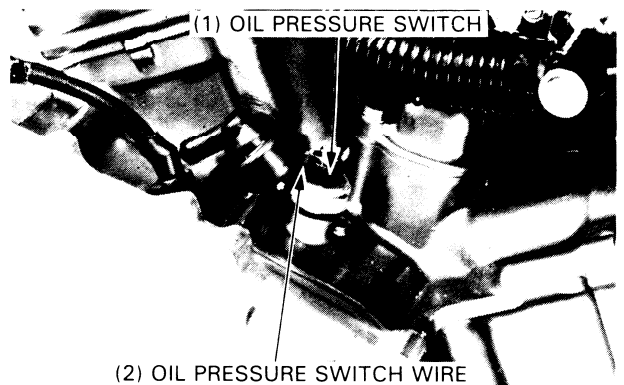

OIL STRAINER CLEANING

NOTE

- The oil strainer can be removed with the engine mounted in the frame.

Remove the lower cowl.
Drain the engine oil (page 2-3).

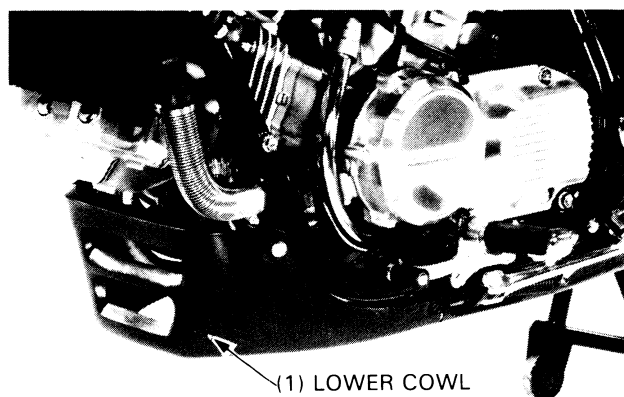

Remove the oil pan bolts and oil pan.

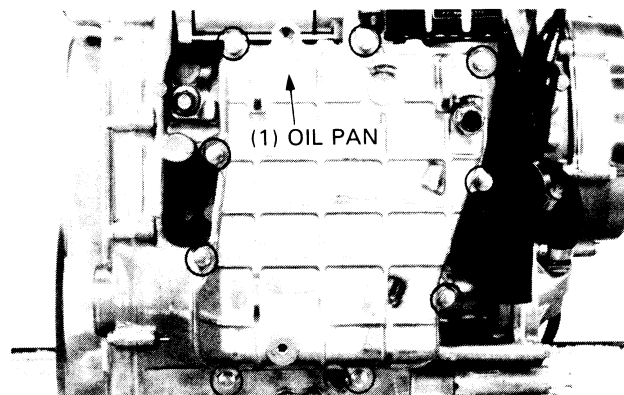

Remove and clean the oil strainer.

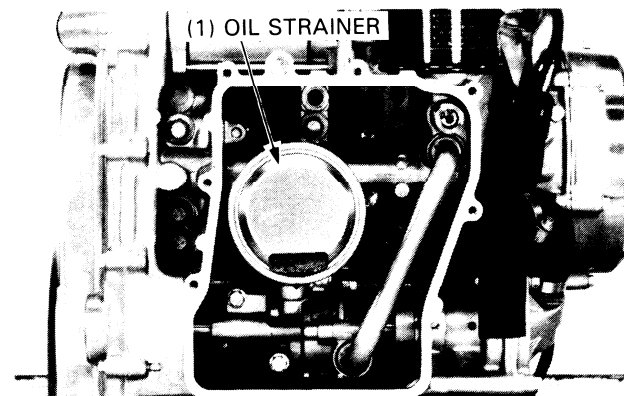

Make sure the oil seal is in good condition.
Install the oil strainer, being careful not to drop the oil seal.

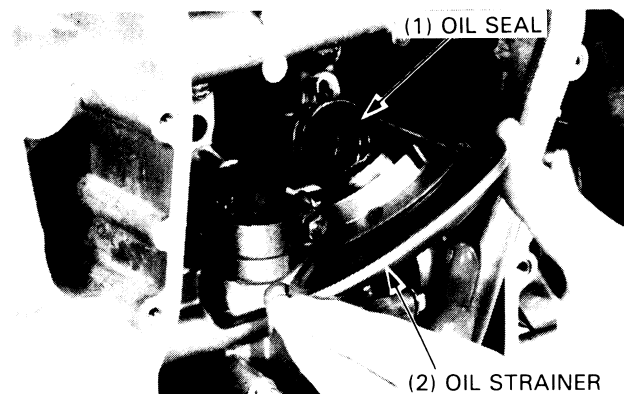

LUBRICATION

Install the oil pan.
Fill the crankcase with the recommended oil (page 2-1).

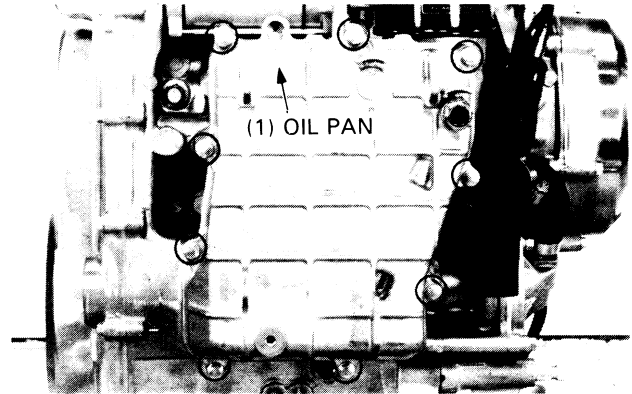

Install the lower cowl.

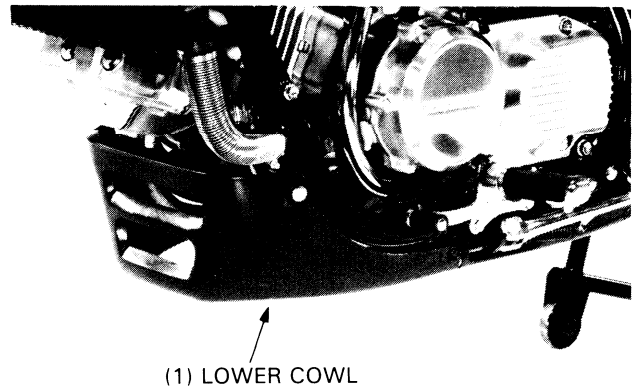

PRESSURE RELIEF VALVE

Remove the lower cowl (page 2-5).
Remove the oil pan bolts and oil pan (page 2-5).
Remove the pressure relief valve.

Check the operation of the pressure relief valve by pushing on the piston.

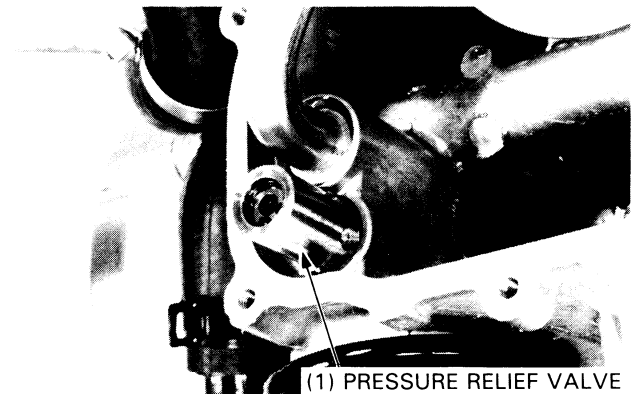

Remove the relief valve circlip and disassemble the relief valve.

Check the spring and piston for wear or damage.
Check the valve for clogging or damage.

Assemble the parts in the reverse order of disassembly.
Be sure to use new O-rings.

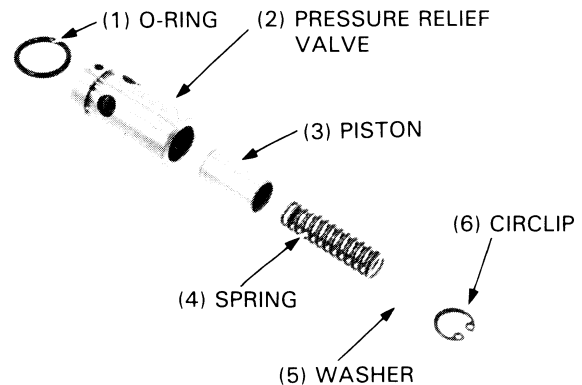

Install the pressure relief valve.
 Install the oil pan (page 2-6).
 Install the exhaust system (page 5-5).
 Fill the crankcase with the recommended oil (page 2-1).
 Install the lower cowl (page 2-6).

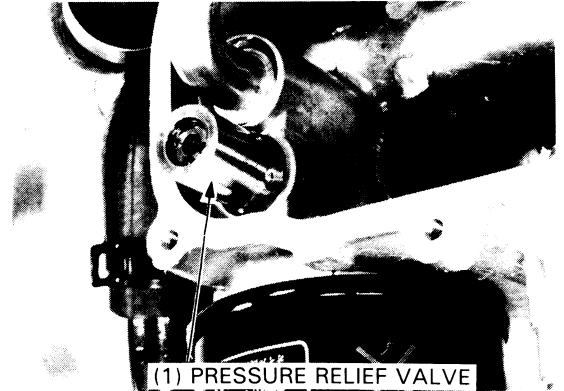

OIL PUMP

REMOVAL

NOTE

- The oil pump can be removed with the engine mounted in the frame.

Drain the engine oil (page 2-3).
 Remove the oil pan (page 2-5).
 Remove the right crankcase cover (page 7-10).
 Remove the oil pump driven sprocket mounting bolt and the oil pump driven sprocket from the oil pump shaft.

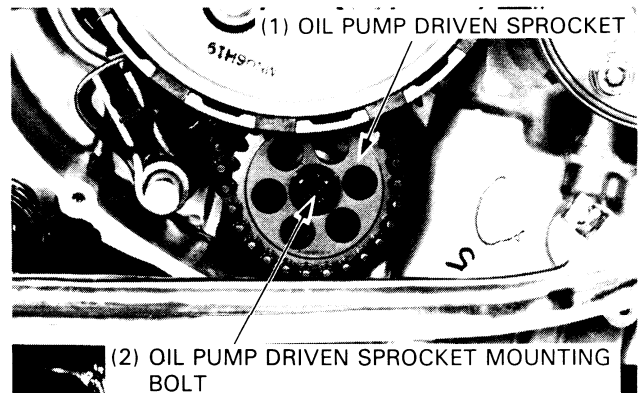

Remove the oil strainer (page 2-5).
 Remove the oil pass pipe.

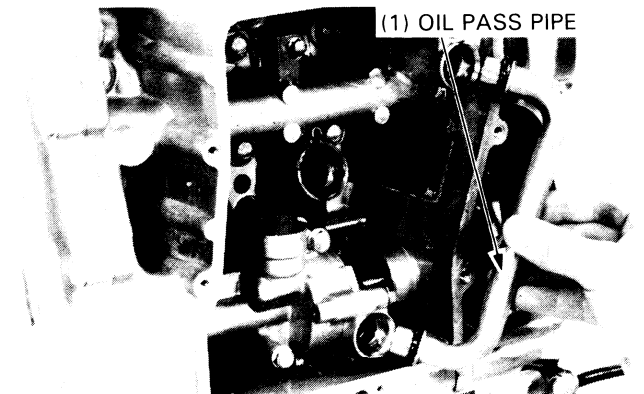

Straighten and remove the pin holding the oil strainer stay.
 Remove the oil strainer stay.
 Make sure the O-rings are in good condition.
 Remove the oil pump by removing the mounting bolts.

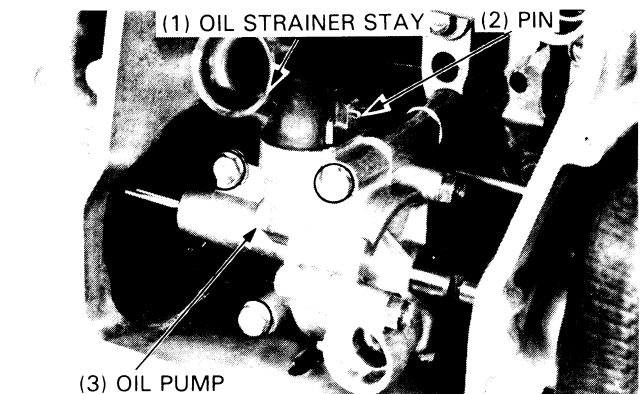

LUBRICATION

Remove the dowel pin and orifice and O-rings.

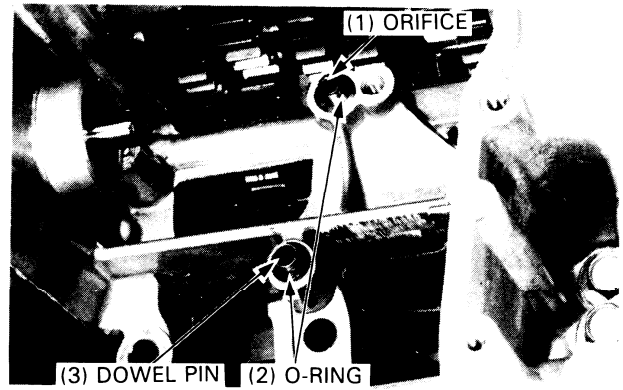

DISASSEMBLY

Remove the three pump cover bolts and oil pump cover.

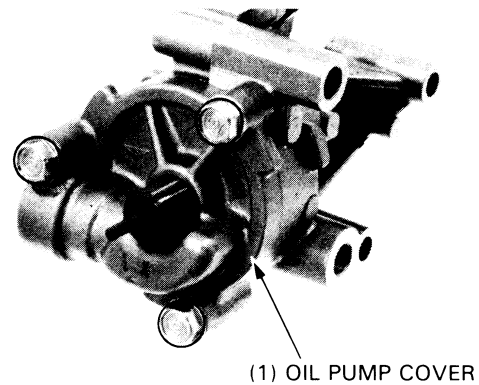

Remove the following:

- Inner and outer rotors from the oil pump body.
- Oil pump shaft from the oil pump body.
- Drive pin from the oil pump shaft.
- Dowel pin and thrust washer.

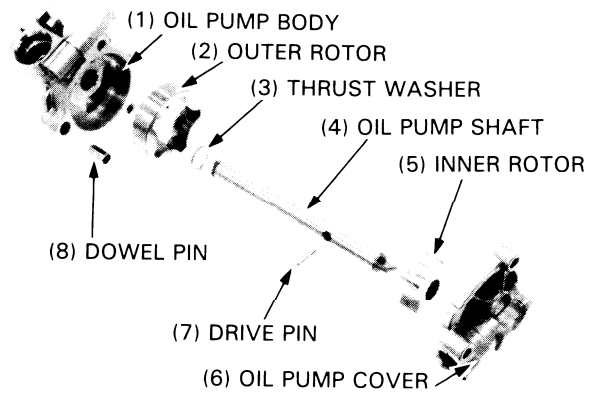

INSPECTION

Install the oil pump shaft, inner and outer rotors into the oil pump body.

Measure the rotor tip clearance.

SERVICE LIMIT: 0.20 mm (0.008 in)

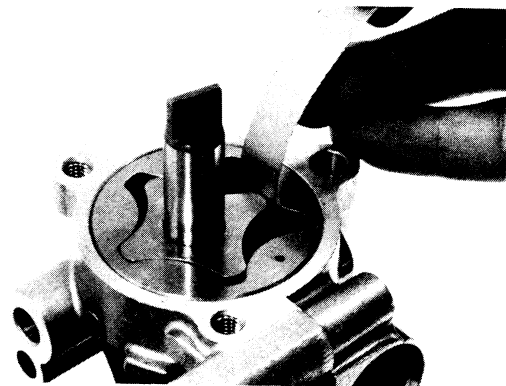

Measure the pump body clearance.

SERVICE LIMIT: 0.35 mm (0.014 in)

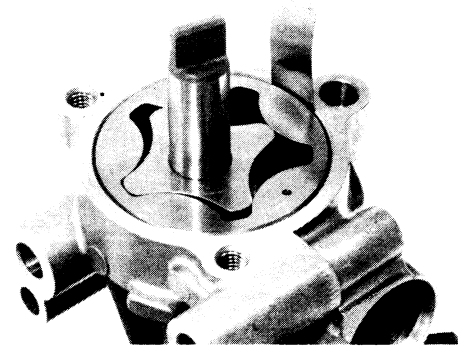

Remove the oil pump shaft and measure the pump end clearance.

SERVICE LIMIT: 0.10 mm (0.004 in)



ASSEMBLY

Install the outer rotor into the oil pump body and insert the oil pump shaft.

NOTF

- Install the outer rotor with its punch mark facing the body cover.

Install the thrust washer.
Insert the drive pin into the oil pump shaft.
Align the slots in the inner rotor with the drive pin.

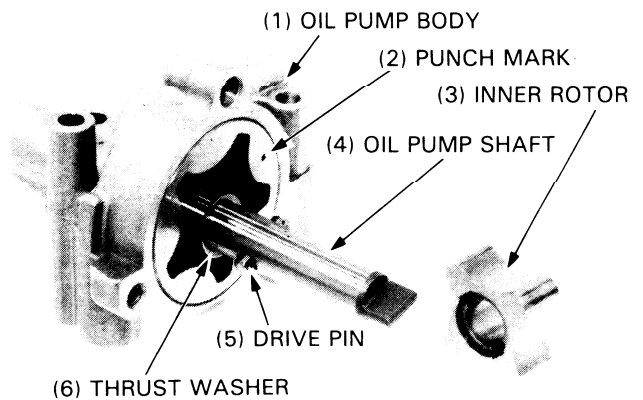

Install the dowel pin and oil pump body cover.

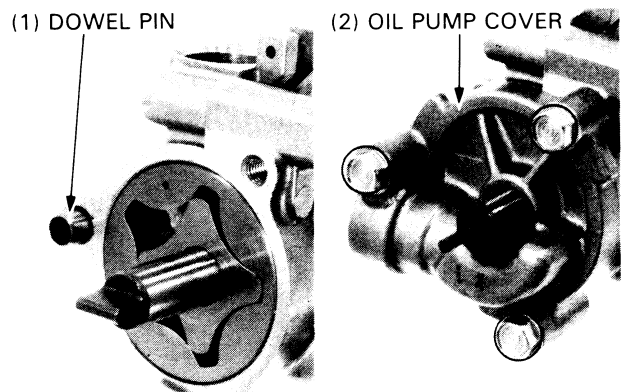

LUBRICATION

Make sure the O-ring is installed on the oil strainer stay.

Install the oil strainer stay using a new pin.

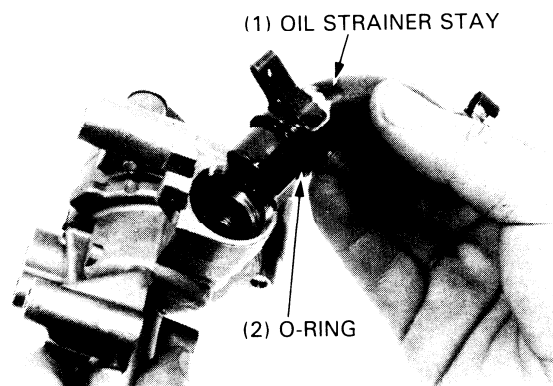

INSTALLATION

Install the orifice, O-rings and dowel pin.

NOTE

- Install the orifice: placing its groove into the oil pump body.

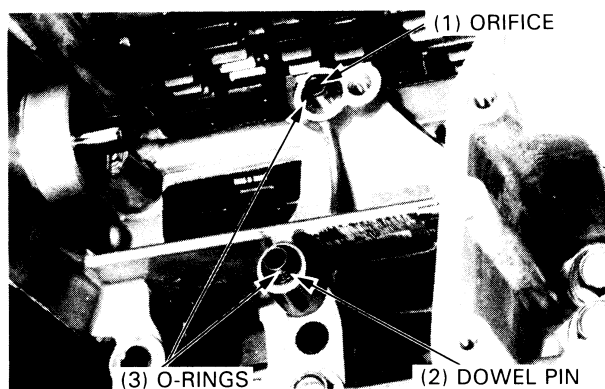

Install the oil pump, aligning the oil pump shaft with the water pump shaft, and tighten the three bolts.

Make sure that the oil pump shaft rotates freely after installing the bolts.

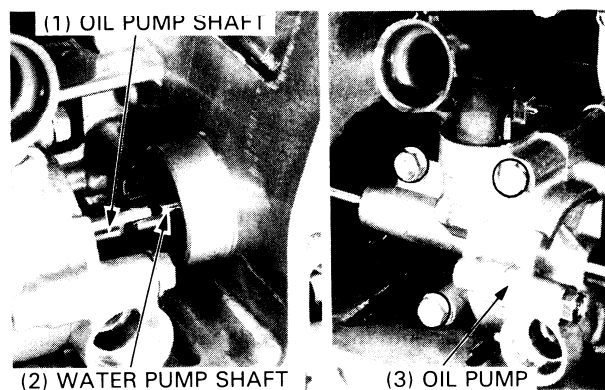

Make sure the O-rings on the oil pass pipe in good condition and install the oil pass pipe.

Install the oil strainer (page 2-5).
Install the oil pan (page 2-6).

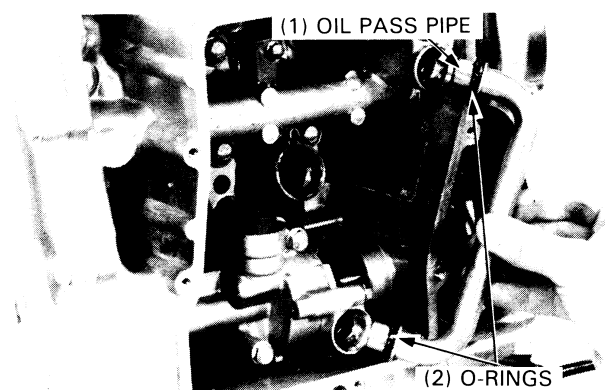

Install the oil pump driven sprocket over the oil pump shaft and secure it with the washer and oil pump driven sprocket mounting bolt.

TORQUE: 15–20 N·m (1.5–2.0 kg-m, 11–14 ft-lb)

Install the right crankcase cover (page 7-20).
Fill the crankcase with the recommended oil (page 2-1).

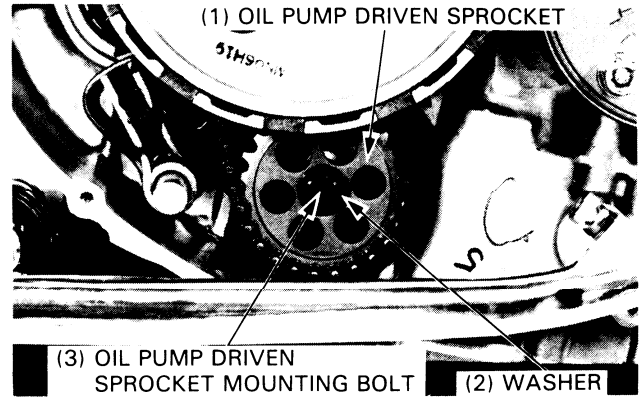

FINAL DRIVE OIL

CHECK

Place a jack or support block under the engine, to raise the rear wheel off the ground.
Remove the oil filler cap.
Check that the oil level reaches the lower edge of the oil filler cap hole.
Check for leaks. If the level is low, fill with fresh oil to the lower edge of the cap hole.

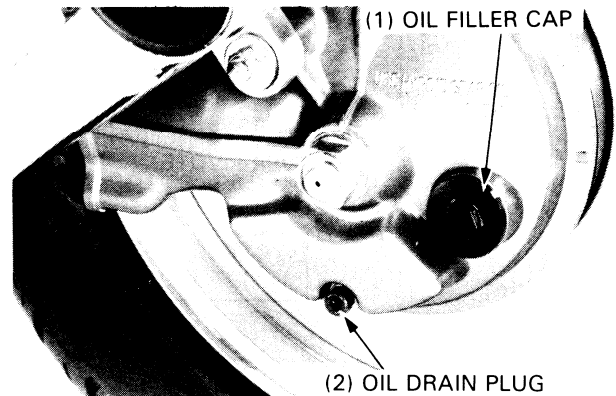

CHANGE

Remove the oil filler cap and drain bolt to drain all oil from the final drive gear case.
Reinstall the sealing washer/drain bolt securely.

TORQUE: 10–14 N·m (1.0–1.4 kg-m, 7–10 ft-lb)

Fill the gear case with the recommended oil up to the correct level.

OIL CAPACITY: 130 cc (4.4 oz)
RECOMMENDED OIL: Hypoid Gear Oil SAE #80

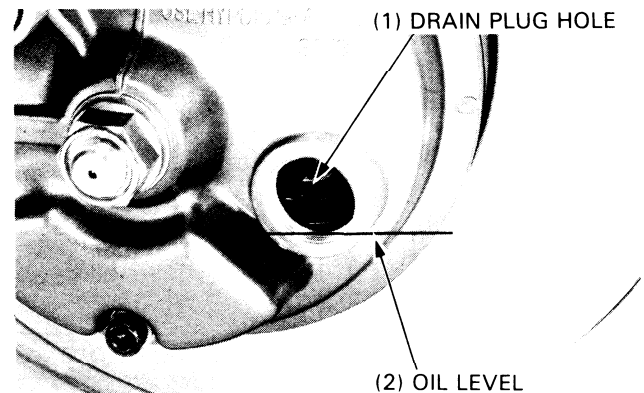

LUBRICATION

LUBRICATION POINTS

Use general purpose when not specified otherwise.
Apply oil or grease to sliding surfaces not shown here.

CONTROL CABLE LUBRICATION

Periodically, disconnect the throttle and choke cables at their upper ends. Thoroughly lubricate the cables with a commercially available cable lubricant or a lightweight oil.

